

Seismic Design of Liquid-Containing Concrete Structures (ACI 350.3-01) and Commentary (350.3R-01)

REPORTED BY ACI COMMITTEE 350

**ACI Committee 350
Environmental Engineering Concrete Structures**

Charles S. Hanskat
Chairman

Nicholas A. Legatos*
Subcommittee Chairman

James P. Archibald
Jon B. Ardahl*
Walter N. Bennett
Steven R. Close
Ashok K. Dhingra*
Anthony L. Felder

A. Ray Frankson
Anand B. Gogate*
William J. Hendrickson*
Jerry A. Holland
William J. Irwin

Dov Kaminetzky
M. Reza Kianoush*
David G. Kittridge
Larry G. Mrazek*
Jerry Parnes

Lawrence M. Tabat*
Secretary

Andrew R. Philip*
Subcommittee Secretary

David M. Rogowsky
Satish K. Sachdev
William C. Schnobrich*
Sudhaker P. Verma
Roger H. Wood

Voting Subcommittee Members

Osama Abdel-Aai*
John Baker

Patrick J. Creegan*

David A. Crocker

Ernst T. Cvikl

Robert E. Doyle

Clifford T. Early

Clifford Gordon

Paul Hedli

Keith W. Jacobson

Dennis C. Kohl

Bryant Mather

Jack Moll

Carl H. Moon

Javeed A. Munshi*

Terry Patzias

Narayan M. Prachand

John F. Seidensticker

William C. Sherman*

Lauren A. Sustic

Lawrence J. Valentine

Miroslav Vejvoda

Paul Zoltanetzky

*Members of ACI 350 Seismic Design Subcommittee who prepared this report.

Seismic Design of Liquid-Containing Concrete Structures (ACI 350.3-01) and Commentary (ACI 350.3R-01)

REPORTED BY ACI COMMITTEE 350

This standard prescribes procedures for the seismic analysis and design of liquid-containing concrete structures. These procedures address the “loading side” of seismic design and shall be used in accordance with ACI 350-01/ACI 350R-01, Chapter 21.

Keywords: circular tanks; concrete tanks; convective component; earthquake resistance; environmental concrete structures; impulsive component; liquid-containing structures; rectangular tanks; seismic resistance; sloshing; storage tanks.

INTRODUCTION

The following outline highlights the development of this document and its evolution to the present format:

- From the time it embarked on the task of developing an “ACI 318-dependent” code, Committee 350 decided to expand on and supplement Chapter 21, “Special Provisions for Seismic Design,” in order to provide a set of thorough and comprehensive procedures for the seismic analysis and design of all types of liquid-containing environmental concrete structures. The committee’s decision was influenced by the recognition that liquid-containing structures are unique structures whose seismic design is not adequately covered by the leading national codes and standards. A seismic design subcommittee was appointed with the charge to implement the committee’s decision.
- The seismic subcommittee’s work was guided by two main objectives: (a) To produce a self-contained set of procedures that would enable a practicing engineer to perform a full seismic analysis and design of a liquid-containing structure. This meant that these procedures

ACI Committee Reports, Guides, Standards, and Commentaries are intended for guidance in planning, designing, executing, and inspecting construction. This Commentary is intended for the use of individuals who are competent to evaluate the significance and limitations of its content and recommendations and who will accept responsibility for the application of the material it contains. The American Concrete Institute disclaims any and all responsibility for the stated principles. The Institute shall not be liable for any loss or damage arising therefrom. Reference to this commentary shall not be made in contract documents. If items found in this Commentary are desired by the Architect/Engineer to be a part of the con-

tract documents, they shall be restated in mandatory language for incorporation by the Architect/Engineer.

should cover both aspects of seismic design: the “loading side” (namely the determination of the seismic loads based on the seismic zone of the site, the specified effective ground acceleration, and the geometry of the structure), and the “resistance side” (the detailed design of the structure in accordance with the provisions of the code, so as to safely resist those loads). (b) To establish the scope of the new procedures consistent with the overall scope of ACI 350. This required the inclusion of all types of tanks—rectangular, as well as circular; and reinforced concrete, as well as prestressed.

[While there are currently at least two national standards that provide detailed procedures for the seismic analysis and design of liquid-containing structures (References 17 and 18), these are limited to circular, prestressed concrete tanks only].

As the “loading side” of seismic design is outside the scope of Chapter 21, ACI 318, it was decided to maintain this practice in ACI 350 as well. Accordingly, the basic scope, format, and mandatory language of Chapter 21 of ACI 318 were retained with only enough revisions to adapt the chapter to environmental engineering structures. This approach offers at least two advantages: (a) It allows ACI 350 to maintain ACI 318’s practice of limiting its seismic design provisions to the “resistance side” only; and (b) it makes it easier to update these seismic provisions so as to keep up with the frequent changes and improvements in the field of seismic hazard analysis and evaluation.

The seismic force levels and R_w -factors included herein provide results at allowable stress levels, such as are included for seismic design in the 1994 Uniform Building Code. When comparing these provisions with other documents defining

tract documents, they shall be restated in mandatory language for incorporation by the Architect/Engineer.

ACI 350.3-01/350.3R-01 became effective on December 11, 2001.

Copyright © 2001, American Concrete Institute.

All rights reserved including rights of reproduction and use in any form or by any means, including the making of copies by any photo process, or by any electronic or mechanical device, printed or written or oral, or recording for sound or visual reproduction or for use in any knowledge or retrieval system or device, unless permission in writing is obtained from the copyright proprietors.

seismic forces at strength levels (for example, the 1997 Uniform Building Code or the 2000 International Building Code), the seismic forces herein should be increased by the applicable factors to derive comparable forces at strength levels.

The user should note the following general design methods used herein, which represent some of the key differences in methods relative to traditional methodologies used, such as in Reference 3: (1) Instead of assuming a rigid tank directly accel-

erated by ground acceleration, this document assumes amplification of response due to natural frequency of the tank; (2) this document includes the response modification factor; (3) rather than combining impulsive and convective modes by algebraic sum, this document combines these modes by square-root-sum-of-the-squares; (4) this document includes the effects of vertical acceleration; and (5) this document includes an effective mass coefficient, applicable to the mass of the walls.

CONTENTS

CHAPTER 1—GENERAL REQUIREMENTS 350.3/350.3R-5

- 1.1—Scope
- 1.2—Notation

CHAPTER 2—TYPES OF LIQUID-CONTAINING STRUCTURES 350.3/350.3R-11

- 2.1—Ground-supported structures
- 2.2—Pedestal-mounted structures

CHAPTER 3—GENERAL CRITERIA FOR ANALYSIS AND DESIGN .. 350.3/350.3R-13

- 3.1—Dynamic characteristics
- 3.2—Design loads
- 3.3—Design requirements

CHAPTER 4—EARTHQUAKE DESIGN LOADS 350.3/350.3R-15

- 4.1—Earthquake pressures above base
- 4.2—Application of site-specific response spectra

CHAPTER 5—EARTHQUAKE LOAD DISTRIBUTION..... 350.3/350.3R-21

- 5.1—General
- 5.2—Shear transfer
- 5.3—Dynamic force distribution above base

CHAPTER 6—STRESSES..... 350.3/350.3R-27

- 6.1—Rectangular tanks
- 6.2—Circular tanks

CHAPTER 7—FREEBOARD 350.3/350.3R-29

- 7.1—Wave oscillation

CHAPTER 8—EARTHQUAKE-INDUCED EARTH PRESSURES 350.3/350.3R-31

- 8.1—General
- 8.2—Limitations
- 8.3—Alternative methods

CHAPTER 9—DYNAMIC MODEL 350.3/350.3R-33

- 9.1—General
- 9.2—Rectangular tanks (Type 1)
- 9.3—Circular tanks (Type 2)
- 9.4—Spectral amplification factors C_i and C_c
- 9.5—Effective mass coefficient ϵ
- 9.6—Pedestal-mounted tanks

CHAPTER 10—COMMENTARY REFERENCES 350.3/350.3R-49

APPENDIX A—DESIGN METHOD 350.3/350.3R-51

- RA.1—General outline of design method

CHAPTER 1—GENERAL REQUIREMENTS

STANDARD

1.1—Scope

This document describes procedures for the design of liquid-containing concrete structures subjected to seismic loads. These procedures shall be used in accordance with Chapter 21 of ACI 350-01.

1.2—Notation

- A_c = spectral acceleration, expressed as a fraction of the acceleration due to gravity, g , from a site-specific response spectrum, corresponding to the natural period of the first (convective) mode of sloshing, T_c , at 0.5% of critical damping
- A_i = spectral acceleration, expressed as a fraction of the acceleration due to gravity, g , from a site-specific response spectrum, corresponding to the natural period of the tank and the impulsive component of the stored liquid, T_i , at 5% of critical damping
- A_s = cross-sectional area of base cable, strand, or conventional reinforcement, in.² (mm²)
- A_v = spectral acceleration, expressed as a fraction of the acceleration due to gravity, g , from a site-specific response spectrum, corresponding to the natural period of vibration of vertical motion, T_v , of the tank and the stored liquid, at 5% of critical damping
- b = ratio of vertical to horizontal design acceleration
- B = inside length of a rectangular tank, perpendicular to the direction of the earthquake force, ft (m)
- C = period-dependent spectral amplification factor (C_c , C_i , or C_v as defined below)
- C_c = period-dependent spectral amplification factor for the horizontal motion of the convective component (for 0.5% of critical damping) (Eq. (9-33))

COMMENTARY

R1.1—Scope

This document is a companion document to Chapter 21 of the American Concrete Institute Committee code 350, “Code Requirements for Environmental Engineering Concrete Structures (ACI 350-01) and Commentary (350R-01).”⁽¹⁾

This document provides directions to the designer of liquid-containing concrete structures for computing seismic forces that are to be applied to the particular structure. The designer should also consider the effects of seismic forces on components outside the scope of this document, such as piping, equipment (for example, clarifier mechanisms), and connecting walkways, where vertical or horizontal movements between adjoining structures or surrounding backfill could adversely influence the ability of the structure to function properly.⁽²⁾ Moreover, seismic forces applied at the interface of piping or walkways with the structure may also introduce appreciable flexural or shear stresses at these connections.

R1.2—Notation

STANDARD

- C_i = period-dependent spectral amplification factor for the horizontal motion of the impulsive component (for 5% of critical damping) (Eq. (9-31) and (9-32))
- C_l, C_w = coefficients for determining the fundamental frequency of the tank-liquid system (see Eq. (9-24) and Fig. 9.10)
- C_v = period-dependent spectral amplification factor for vertical motion of the contained liquid (Eq. (4-16))
- d, d_{max} = freeboard (sloshing height) measured from the liquid surface at rest, ft (m)
- D = inside diameter of circular tank, ft (m)
- EBP = Excluding Base Pressure (datum line just above the base of the tank wall)
- E_c = modulus of elasticity of concrete, lb/in.² (MPa)
- E_s = modulus of elasticity of cable, wire, strand, or conventional reinforcement, lb/in.² (MPa)
- G_p = shear modulus of elastomeric bearing pad, lb/in.² (MPa)
- g = acceleration due to gravity [32.17 ft/s² (9.807 m/s²)]
- h_c (EBP),
 h_c (IBP) = height above the base of the wall to the center of gravity of the convective lateral force, ft (m)
- h_i (EBP),
 h_i (IBP) = height above the base of the wall to the center of gravity of the impulsive lateral force, ft (m)
- h_r = height from the base of the wall to the center of gravity of the tank roof, ft (m)
- h_w = height from the base of the wall to the center of gravity of the tank shell, ft (m)
- H_L = design depth of stored liquid, ft (m)
- H_w = wall height (inside dimension), ft (m)
- I = importance factor, from Table 4(c)
- IBP = Including Base Pressure (datum line at the base of the tank including the effects of the tank bottom and supporting structure)
- k = flexural stiffness of a unit width of a rectangular tank wall, lb/ft² (kPa)
- k_a = spring constant of the tank wall support system, lb/ft² (kPa)
- K_a = active coefficient of lateral earth pressure
- K_o = coefficient of lateral earth pressure at rest
- L = inside length of a rectangular tank, parallel to the direction of the earthquake force, ft (m)
- L_p = length of individual elastomeric bearing pads, in. (mm)
- L_s = effective length of base cable or strand taken as the sleeve length plus 35 times the strand diameter, in. (mm)
- m = mass = $m_i + m_w$ lb-s²/ft⁴ (kN.s²/m⁴)

COMMENTARY

EBP refers to the hydrodynamic design in which it is necessary to compute the overturning of the wall with respect to the tank floor, excluding base pressure (that is, excluding the pressure on the floor itself). EBP hydrodynamic design is used to determine the need for hold-downs in non-fixed base tanks. EBP is also used in determining the design pressure acting on walls. (For explanation, see Reference 3)

h = as defined in R9.2.4, ft (m)

IBP refers to the hydrodynamic design in which it is necessary to investigate the overturning of the entire structure with respect to the foundation. IBP hydrodynamic design is used to determine the design pressure acting on the tank floor and the underlying foundation. This pressure is transferred directly either to the subgrade or to other supporting structural elements. IBP accounts for moment effects due to dynamic fluid pressures on the bottom of the tank by increasing the effective vertical moment arm to the applied forces. (For explanation, see Reference 3)

STANDARD

COMMENTARY

- m_i = impulsive mass of contained liquid per unit width of a rectangular tank wall, lb-s²/ft⁴ (kN.s²/m⁴)
- m_w = mass per unit width of a rectangular tank wall, lb-s²/ft⁴ (kN.s²/m⁴)
- M_b = bending moment on the entire tank cross section just above the base of the tank wall, ft-lb (N.m)
- M_o = overturning moment at the base of the tank including the tank bottom and supporting structure, ft-lb (kN.m)
- N_{cy} = in circular tanks, hoop force at liquid level y , due to the convective component of the accelerating liquid, pounds per foot of wall height (kN/m)
- N_{hy} = in circular tanks, hydrodynamic hoop force at liquid level y , due to the effect of vertical acceleration, pounds per foot of wall height (kN/m)
- N_{iy} = in circular tanks, hoop force at liquid level y , due to the impulsive component of the accelerating liquid, pounds per foot of wall height (kN/m)
- N_y = in circular tanks, total effective hoop force at liquid level y , pounds per foot of wall height (kN/m)
- N_{wy} = in circular tanks, hoop force at liquid level y , due to the inertia force of the accelerating wall mass, pounds per foot of wall height (kN/m)

- p_{vy} = unit equivalent hydrodynamic pressure due to the effect of vertical acceleration, at liquid level y , above the base of the tank ($p_{vy} = \ddot{u}_v \times q_{hy}$), lb/ft² (kPa)
- P_c = total lateral convective force associated with W_c , lb (kN)
- P_{cy} = lateral convective force due to W_c , per unit height of the tank wall, occurring at liquid level y , pounds per ft. of wall height (kN/m)
- P_h = total hydrostatic force occurring on length B of a rectangular tank or diameter D of a circular tank, lb (kN)
- P_{hy} = lateral hydrostatic force per unit height of the tank wall, occurring at liquid level y , pounds per ft. of wall height (kN/m)
- P_i = total lateral impulsive force associated with W_i , lb (kN)
- P_{iy} = lateral impulsive force due to W_i , per unit height of the tank wall, occurring at level y above the tank base, pounds per foot of wall height (kN/m)

- p_{cy} = unit lateral dynamic convective pressure distributed horizontally at liquid level y , lb/ft² (kPa)
- p_{iy} = unit lateral dynamic impulsive pressure distributed horizontally at liquid level y , lb/ft² (kPa)
- p_{wy} = unit lateral inertia force due to wall dead weight, distributed horizontally at liquid level y , lb/ft² (kPa)

For a schematic representation of P_h , see Fig. R5.4.

STANDARD

- P_r = lateral inertia force of the accelerating roof, W_r , lb (kN)
- $P_{w\zeta}$ = in a rectangular tank, lateral inertia force of one accelerating wall ($W_{w\zeta}$), perpendicular to the direction of the earthquake force, lb (kN)
- P_w = lateral inertia force of the accelerating wall, W_w , lb (kN)
- P_{wy} = lateral inertia force due to W_w , per unit height of the tank wall, occurring at level y above the tank base, pounds per foot of wall height (kN/m)
- P_y = combined horizontal force (due to the impulsive and convective components of the accelerating liquid; the wall's inertia; and the hydrodynamic pressure due to the vertical acceleration) at a height y above the tank base, pounds per foot of wall height (kN/m)
- q_{hy} = unit hydrostatic pressure at liquid level y above the tank base [$q_{hy} = g_L (H_L - y)$], lb/ft² (kPa)
- R = inside radius of circular tank, ft (m)
- R_w = response modification factor, a numerical coefficient representing the combined effect of the structure's ductility, energy-dissipating capacity, and structural redundancy (R_{wc} for the convective component of the accelerating liquid; R_{wi} for the impulsive component) from Table 4(d)
- s = seconds
- S = site profile coefficient representing the soil characteristics as they pertain to the structure, from Table 4(b)
- S_p = center-to-center spacing of elastomeric bearing pads, in. (mm)
- S_s = center-to-center spacing between individual base cable loops, in. (mm)
- t_p = thickness of elastomeric bearing pads, in. (mm)
- t_w = average wall thickness, in. (mm)
- T_c = natural period of the first (convective) mode of sloshing, s
- T_i = fundamental period of oscillation of the tank (plus the impulsive component of the contents), s
- T_v = natural period of vibration of vertical liquid motion, s
- \ddot{u}_v = effective spectral acceleration from an inelastic vertical response spectrum, as defined by Eq. (4-15), that is derived by scaling from an elastic horizontal response

COMMENTARY

- q, q_{max} = unit shear force in circular tanks, lb/ft
- Q = total membrane (tangential) shear force at the base of a circular tank, lb (kN)
- Q_{hy} = in circular tanks, hydrostatic hoop force at liquid level y ($Q_{hy} = q_{hy} \times R$), pounds per foot of wall height (kN/m)
- S_D = spectral displacement, ft (m)

STANDARD

COMMENTARY

spectrum, expressed as a fraction of the acceleration due to gravity, g

V = total horizontal base shear, lb (kN)

w_p = width of elastomeric bearing pad, in. (mm)

W_c = equivalent mass of the convective component of the stored liquid, lb (kN)

W_e = effective dynamic mass of the tank structure (walls and roof) ($W_e = (eW_w + W_r)$), lb (kN)

W_i = equivalent mass of the impulsive component of the stored liquid, lb (kN)

W_L = total mass of the stored liquid, lb (kN)

W_r = mass of the tank roof, plus superimposed load, plus applicable portion of snow load considered as dead load, lb (kN)

W_w = mass of the tank wall (shell), lb (kN)

W'_w = in a rectangular tank, the mass of one wall perpendicular to the direction of the earthquake force, lb (kN)

y = liquid level at which the wall is being investigated (measured from tank base), ft (m)

Z = seismic zone factor, from Table 4(a)

α = angle of base cable or strand with horizontal, degrees

b = percent of critical damping

g_c = specific weight of concrete, [150 lb/ft³ (23.56 kN/m³) for standard-weight concrete]

g_L = specific weight of contained liquid, lb/ft³ (kN/m³)

g_w = specific weight of water, 62.43 lb/ft³ (9.807 kN/m³)

e = effective mass coefficient (ratio of equivalent dynamic mass of the tank shell to its actual total mass). Eq. (9-34) and (9-35).

q = polar coordinate angle, degrees

l = coefficient as defined in 9.2.4 and 9.3.4

r_c = mass density of concrete [4.66 lb-s²/ft⁴ (2.40 kN.s²/m⁴) for standard-weight concrete]

r_L = mass density of the contained liquid ($r_L = g_L/g$), lb-s²/ft⁴ (kN.s²/m⁴)

r_w = mass density of water [1.94 lb-s²/ft⁴ (1.0 kN.s²/m⁴)]

s_y = membrane (hoop) stress in wall of circular tank at liquid level y , lb/in.² (MPa)

w_c = circular frequency of oscillation of the first (convective) mode of sloshing, rad/s

w_i = circular frequency of the impulsive mode of vibration, rad/s

“Equivalent mass”, “ W ” = mass \times acceleration due to gravity, g .

In the SI system, “equivalent mass”, “ W ” = [mass (kg) \times 9.80665 m/s²]/1000 = kN

h_c, h_i = coefficients as defined in R4.2

For q see Fig. R5.1 and R5.2

Notes

CHAPTER 2—TYPES OF LIQUID-CONTAINING STRUCTURES

STANDARD

2.1—Ground-supported structures

Structures in this category include rectangular and circular liquid-containing concrete structures, on-grade and below grade.

2.1.1—Ground-supported liquid-containing structures are classified according to this section on the basis of the following characteristics:

- General configuration (rectangular or circular)
- Wall-base joint type (fixed, hinged, or flexible base)
- Method of construction (reinforced or pre-stressed concrete)

1. Rectangular tanks

Type 1.1 Fixed base

Type 1.2 Hinged base

2. Circular tanks

Type 2.1 Fixed base

2.1(1) Reinforced concrete

2.1(2) Prestressed concrete

Type 2.2 Hinged base

2.2(1) Reinforced concrete

2.2(2) Prestressed concrete

Type 2.3 Flexible base (prestressed only)

2.3(1) Anchored

2.3(2) Unanchored, contained

2.3(3) Unanchored, uncontained

2.2—Pedestal-mounted structures

Structures in this category include liquid-containing structures mounted on cantilever-type pedestals.

COMMENTARY

R2.1—Ground-supported structures

For basic configurations of ground-supported, liquid-containing structures, see Fig. R2.1

R2.1.1—The classifications of 2.1.1 are based on the wall-to-footing connection details as illustrated in Fig. R2.2.

With any one of the tank types covered under this report, the floor may be a membrane-type slab, a raft foundation, or a structural slab supported on piles.

The tank roof may be a free-span dome or column-supported flat slab; or the tank may be open-topped.

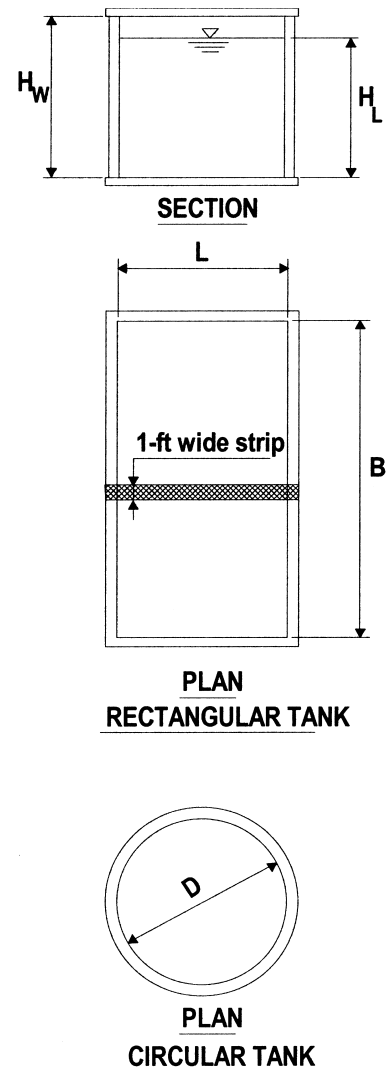
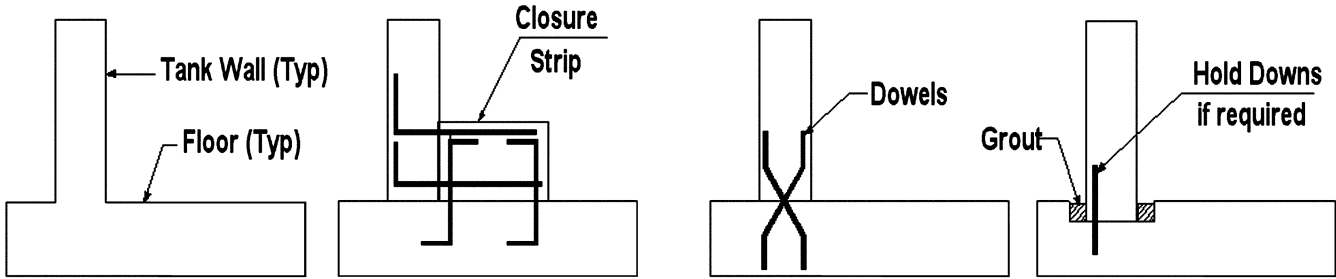

Fig. R2.1—Typical tank configurations (adapted from Reference 4).



FIXED

TYPE 1.1 OR 2.1

HINGED OR PINNED

TYPE 1.2 OR 2.2

NONFLEXIBLE BASE CONNECTIONS

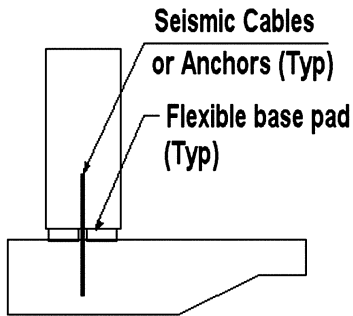

**ANCHORED
 FLEXIBLE BASE
 TYPE 2.3(1)**

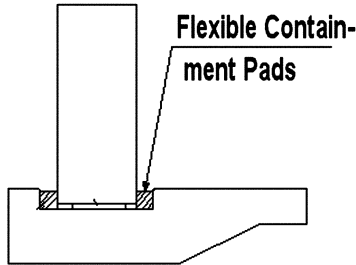

**UNANCHORED, CONTAINED
 FLEXIBLE BASE
 TYPE 2.3(2)**

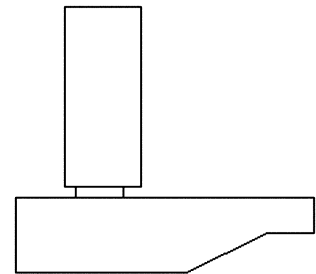

**FLEXIBLE BASE
 TYPE 2.3(3)**

FLEXIBLE BASE CONNECTIONS

Fig. R2.2—Types of ground-supported, liquid-containing structures classified on the basis of their wall-to-footing connection details (base waterstops not shown).

CHAPTER 3 — GENERAL CRITERIA FOR ANALYSIS AND DESIGN

STANDARD

COMMENTARY

3.1—Dynamic characteristics

The dynamic characteristics of liquid-containing structures shall be derived in accordance with either [Chapter 9](#) or a more rigorous dynamic analysis that accounts for the interaction between the structure and the contained liquid.

3.2—Design loads

The loads generated by the design earthquake shall be computed in accordance with [Chapter 4](#).

3.3—Design requirements

3.3.1—The walls, floors and roof of liquid-containing structures shall be designed to withstand the effects of both the design horizontal acceleration and the design vertical acceleration combined with the effects of the applicable design static loads.

3.3.2—With regards to the horizontal acceleration, the design shall take into account: the effects of the transfer of the total base shear between the wall and the footing, and between the wall and the roof; and the dynamic pressure acting on the wall above the base.

3.3.3—Effects of maximum horizontal and vertical acceleration shall be combined by the square root of the sum of the squares method.

Notes

CHAPTER 4—EARTHQUAKE DESIGN LOADS

STANDARD

4.1—Earthquake pressures above base

The walls of liquid-containing structures shall be designed for the following dynamic forces in addition to the static pressures: (a) inertia forces P_w and P_r ; (b) hydrodynamic impulsive pressure P_i from the contained liquid; (c) hydrodynamic convective pressure P_c from the contained liquid; (d) dynamic earth pressure from saturated and unsaturated soils against the buried portion of the wall; and (e) the effects of vertical acceleration.

4.1.1—Dynamic lateral forces

The dynamic lateral forces above the base shall be determined as follows:

$$P_w = ZSIC_i \cdot \frac{eW_w}{R_{wi}} \quad (4-1)$$

$$P_w \zeta = ZSIC_i \cdot \frac{eW_w \zeta}{R_{wi}} \quad (4-1a)$$

$$P_r = ZSIC_i \cdot \frac{W_r}{R_{wi}} \quad (4-2)$$

$$P_i = ZSIC_i \cdot \frac{W_i}{R_{wi}} \quad (4-3)$$

$$P_c = ZSIC_c \cdot \frac{W_c}{R_{wc}} \quad (4-4)$$

Where applicable, the lateral forces due to the dynamic earth and ground water pressures against the buried portion of the walls shall be computed in accordance with the provisions of [Chapter 8](#).

4.1.2—Total base shear, general equation

The base shear due to seismic forces applied at the bottom of the tank wall shall be determined by the following equation:

$$V = \sqrt{(P_i + P_w + P_r)^2 + P_c^2} \quad (4-5)$$

COMMENTARY

R4.1—Earthquake pressures above base

The general equation for the total base shear normally encountered in the earthquake-design sections of governing building codes

$\left[V = \frac{ZIC}{R_w} \cdot W \right]$ is modified in Eq. (4-1) through (4-4) by

replacing the term W with the four effective masses: the effective mass of the tank wall, eW_w , and roof, W_r ; the impulsive component of the liquid mass W_i ; and the convective component W_c . Because the impulsive and convective components are not in phase with each other, normal practice is to combine them using the square root of the sum of the squares method (Eq. (4-5)).

The general equation for base shear is also modified in Eq. (4-1) through (4-4) by the soil profile coefficient S in accordance with Table 4(b).

The imposed ground motion is represented by an elastic response spectrum that is either derived from an actual earthquake record for the site, or is constructed by analogy to sites with known soil and seismic characteristics. The profile of the response spectrum is defined by the product ZC . Factor Z ([Table 4\(a\)](#)) represents the maximum effective peak ground acceleration for the site, while C is a period-dependent spectral-amplification factor. In Eq. (4-1) to (4-4) factor C is represented by C_i and C_c , corresponding to the responses of the impulsive and convective components, respectively.

Factor I provides a means for the engineer to increase the factor of safety for the categories of structures described in [Table 4\(c\)](#). (See also Reference 1, Section R21.2.1.7). The response modification factors R_{wc} and R_{wi} reduce the elastic response spectrum to account for the structure's ductility, energy-dissipating properties, and redundancy (Reference 1, Section R21.2.1). The resulting inelastic response spectrum is represented by $ZISC/R_w$.

STANDARD**COMMENTARY**

Where applicable, the lateral forces due to dynamic earth and ground water pressures against the buried portion of the walls shall be included in the determinations of the total base shear V .

4.1.3—Moments at base, general equation

The moments due to seismic forces at the base of the tank shall be determined by Eq. (4-10) and (4-13).

Bending moment on the entire tank cross section just above the base of the tank wall (EBP):

$$M_w = P_w \cdot h_w \quad (4-6)$$

$$M_r = P_r \cdot h_r \quad (4-7)$$

$$M_i = P_i \cdot h_i \quad (4-8)$$

$$M_c = P_c \cdot h_c \quad (4-9)$$

$$M_b = \sqrt{(M_i + M_w + M_r)^2 + M_c^2} \quad (4-10)$$

Overturning moment at the base of the tank, including the tank bottom and supporting structure (IBP):

$$M_w = P_w \cdot h_w \quad (4-6)$$

$$M_r = P_r \cdot h_r \quad (4-7)$$

$$M_i \zeta = P_i \cdot h_i \zeta \quad (4-11)$$

$$M_c \zeta = P_c \cdot h_c \zeta \quad (4-12)$$

$$M_o = \sqrt{(M_i \zeta + M_w + M_r)^2 + M_c \zeta^2} \quad (4-13)$$

Where applicable, the effect of dynamic soil and ground water pressures against the buried portion of the walls shall be included in the determination of the moments at the base of the tank.

4.1.4—Vertical acceleration

4.1.4.1—The tank shall be designed for the effects of vertical acceleration. In the absence of a site-specific response spectrum, the ratio b of the vertical to horizontal acceleration shall not be less than 2/3.

4.1.4.2—The hydrostatic load q_{hy} from the tank contents shall be multiplied by the spectral acceleration \ddot{u}_v to account for the effect of the vertical acceleration.

Energy Method: An energy method of dynamic analysis may be used instead of the base-shear approach of 4.1 for sizing earthquake cables and base pad for flexible base joints. (5), (6), (7), (8), (9), (10)

R4.1.4—Vertical acceleration

The effective fluid pressure will be increased or decreased due to the effects of vertical acceleration. Similar changes in effective weight of the concrete structure may also be considered.

The resulting hydrodynamic pressure p_{hy} shall be computed as follows

$$p_{hy} = \ddot{u}_v \cdot q_{hy} \quad (4-14)$$

where

$$\ddot{u}_v = ZSC_v I \frac{b}{R_{wi}} \quad (4-15)$$

For rectangular tanks, $C_v = 1.0$

For circular tanks,

$$C_v = \frac{1.25}{T_v^{2.75}} \leq \frac{2.75}{S} \quad (4-16)$$

where

$$T_v = 2p \sqrt{\frac{g_L D H_L^2}{24 g t_w E_c}} \quad (4-17)$$

$$[T_v = 2p \sqrt{\frac{g_L D H_L^2}{2 g t_w E_c}} \text{ in SI system}]$$

4.2—Application of site-specific response spectra

4.2.1—Site-specific elastic response spectra shall be constructed for ground motions having a maximum 10% probability of exceedance in 50 years and 5% damping (damping ratio $b = 5$) for the impulsive component, and 0.5% damping (damping ratio $b = 0.5$) for the convective component.

4.2.2—Where site-specific elastic response spectra are used, the force equations (4-1), (4-2), (4-3) and (4-4) shall be modified by substituting A_i , corresponding to T_i , for ZSC_i , and A_c , corresponding to T_c , for ZSC_c ; and Eq. (4-15) shall be modified by substituting A_v , corresponding to T_v , for ZSC_v . The computed forces shall not be less than 80% of those obtained by using Eq. (4-1), (4-2), (4-3), (4-4), (4-5) or (4-15).

R4.2—Application of site-specific response spectra

R4.2.1—In Seismic Zone 4, site-specific response spectra are normally used.

R4.2.2— A_i is the spectral acceleration in g s, corresponding to the natural period of horizontal motion, T_i , of the tank and the impulsive component of the stored liquid, and obtained from a site-specific response spectrum at 5% of critical damping.

A_v is the spectral acceleration in g s, corresponding to the natural period of vibration of vertical motion, T_v , of the tank and the stored liquid, and obtained from a site-specific response spectrum at 5% of critical damping.

When the available site-specific response spectrum is for a damping ratio b other than 5% of critical, the period-dependent spectral accelerations A_i or A_v given by such site-specific spectrum should be modified by the factor h_i to account for the influence of damping on the spectral amplification as follows (see Reference 11):

STANDARD

COMMENTARY

For $0 \text{ s} < (T_i \text{ or } T_v) < 0.31 \text{ s}$,

$$h_i = \frac{2.706}{4.38 - 1.04 \ln b}$$

For $0.31 \text{ s} < (T_i \text{ or } T_v) < 4.0 \text{ s}$,

$$h_i = \frac{2.302}{3.38 - 0.67 \ln b}$$

For $b = 5\%$, $h_i = 1.0$

A_c is the spectral acceleration in g s corresponding to the period T_c , of the first (convective) mode of sloshing, and obtained from a site-specific response spectrum at 0.5% of critical damping.

When the available site-specific response spectrum is for a damping ratio b other than 0.5% of critical, the period-dependent spectral acceleration A_c given by that spectrum should be modified by the ratio h_c to account for the influence of damping on the spectral amplification as follows

$$h_c = \frac{3.043}{2.73 - 0.45 \ln b}$$

For $b = 0.5\%$, $h_c = 1.0$

For site-specific response spectra drawn on a tripartite logarithmic scale, the design spectral acceleration A_c can also be derived by using the relationship

$$A_c = h_c \frac{S_D}{g} \left(\frac{2p}{T_c} \right)^2 = h_c \frac{1.226 S_D}{T_c^2}$$

where S_D is the spectral displacement corresponding to T_c obtained directly from the site-specific spectrum in the range $T_c > 4 \text{ s}$.

The use of a site-specific response spectrum represents one specific case of an “accepted alternate method of analysis” permitted in Chapter 21, Section 21.2.1.6, of ACI 350-01. Therefore, the 80% lower limit imposed in 4.2.2 should be considered the same as the limit imposed in Section 21.2.1.6(a) of ACI 350-01.

SEISMIC DESIGN OF LIQUID-CONTAINING CONCRETE STRUCTURES 350.3/350.3R-19
STANDARD

Table 4(a)—Seismic zone factor Z^*

Seismic map zone [†]	Factor Z
1	0.075
2A	0.15
2B	0.2
3	0.3
4	0.4

*The seismic zone factor Z represents the maximum effective peak acceleration (EPA) corresponding to a ground motion having a 90% probability of not being exceeded in a 50-year period.¹²

[†]See Fig. 4.1.

Table 4(b)—Soil profile coefficient S

Type	Soil profile description	Coefficient
A	A soil profile with either: (a) a rock-like material characterized by a shear wave velocity greater than 2500 ft/s (762 m/s), or by other suitable means of classification; or (b) medium-dense to dense or medium-stiff to stiff soil conditions where the soil depth is less than 200 ft (60 960 mm).	1.0
B	A soil profile with predominantly medium-dense to dense or medium-stiff to stiff soil conditions, where the soil depth exceeds 200 ft (60 960 mm).	1.2
C	A soil profile containing more than 20 ft (6096 mm) of soft to medium-stiff clay but not more than 40 ft (12 192 mm) of soft clay.	1.5
D	A soil profile containing more than 40 ft (12 192 mm) of soft clay characterized by a shear wave velocity less than 500 ft/s (152.4 m/s).	2.0

Note: The site factor shall be established from properly substantiated geotechnical data. In locations where the soil properties are not known in sufficient detail to determine the soil profile, Type C shall be used. Soil Profile D need not be assumed unless the building official determines that Soil Profile D may be present at the site, or in the event that Soil Profile D is established by geotechnical data.

Table 4(c)—Importance factor I

Tank use	Factor I
Tanks containing hazardous materials*	1.5
Tanks that are intended to remain usable for emergency purposes after an earthquake, or tanks that are part of lifeline systems.	1.25
All other tanks	1.0

*For tanks containing hazardous materials, engineering judgment may require a factor $I > 1.5$ to account for the possibility of an earthquake greater than the design earthquake.

Table 4(d)—Response modification factor R_w

Type of structure	R_{wi} on or above grade	Buried*	R_{wc}
(a) Anchored, flexible-base tanks	4.5	4.5 [†]	1.0
(b) Fixed- or hinged-base tanks	2.75	4.0	1.0
(c) Unanchored, contained, or uncontained tanks [‡]	2.0	2.75	1.0
(d) Elevated tanks	3.0	—	1.0

*Buried tank is defined as a tank whose maximum water surface at rest is at or below ground level. For partially buried tanks, the R_{wi} value may be linearly interpolated between that shown for tanks on grade, and for buried tanks.

[†] $R_{wi} = 4.5$ is the maximum R_{wi} value permitted to be used for any liquid-containing concrete structure.

[‡]Unanchored, uncontained tanks may not be built in Zones 2B or higher.

STANDARD

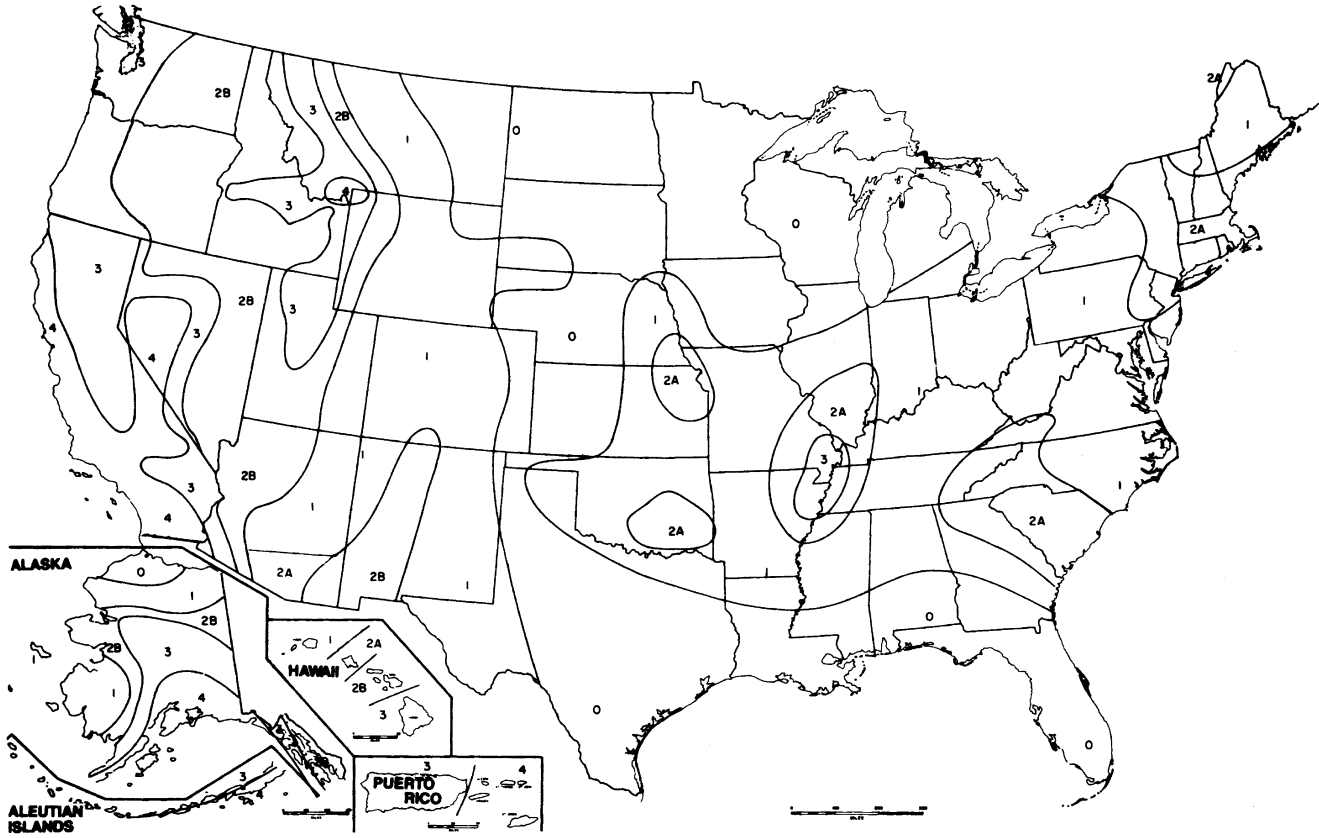

Fig. 4.1—Seismic zone map of the U.S. (Reference 12).

CHAPTER 5—EARTHQUAKE LOAD DISTRIBUTION

STANDARD

COMMENTARY

5.1—General

In the absence of a more rigorous analysis that takes into account the complex vertical and horizontal variations in hydrodynamic pressures, liquid-containing structures shall be designed for the following dynamic shear and pressure distributions in addition to the static load distributions:

5.2—Shear transfer

5.2.1—Rectangular tanks

The wall-to-floor, wall-to-wall, and wall-to-roof joints of rectangular tanks shall be designed for the earthquake shear forces on the basis of the following shear-transfer mechanism:

Walls perpendicular to the direction of the earthquake force shall be analyzed as slabs subjected to the horizontal pressures computed in 5.3. The shears along the bottom and side joints, and the top joint in case of a roof-covered tank, shall correspond to the slab reactions.

Walls parallel to the direction of the earthquake force shall be analyzed as shear walls subjected to the in-plane forces computed in 5.3.

5.2.2—Circular tanks

The wall-to-footing and wall-to-roof joints shall be designed for the earthquake shear forces.

R5.2— Shear transfer (**Reference 13**)

The horizontal earthquake force V generates shear forces between the wall and footing, and the wall and roof.

R5.2.1—Rectangular tanks

Typically, the distribution of forces and wall reactions in rectangular tank walls will be similar to that shown in **Fig. R5.2**

R5.2.2—Circular tanks

In fixed- and hinged-base circular tanks (Types 2.1 and 2.2), the earthquake base shear is transmitted partially by membrane (tangential) shear and the rest by radial shear that causes vertical bending. For a tank with a height-to-diameter ratio of 1:4 ($D/H_L = 4.0$), approximately 20% of the earthquake shear force is transmitted by the radial base reaction to vertical bending. The remaining 80% is transmitted by tangential shear transfer Q . To transmit this tangential shear, Q , a distributed shear force, q , is required at the wall/footing interface, where

$$q = \frac{Q}{pR} \sin \alpha$$

The distribution is illustrated in **Fig. R5.1**

The maximum tangential shear occurs at a point on the tank

STANDARD

COMMENTARY

wall oriented 90 degrees to the design earthquake direction being evaluated, and is given by

$$q_{max} = \frac{Q}{pR} = \frac{0.8V}{pR}$$

The radial shear is created by the flexural response of the wall near the base, and is therefore proportional to the hydrodynamic forces shown in Fig. R5.2. The radial shear attains its maximum value at points on the tank wall oriented 0 and 180 degrees to the ground motion and should be determined using cylindrical shell theory and the tank dimensions. The design of the wall-footing interface should take the radial shear into account.

In general, the wall-footing interface should have reinforcement designed to transmit these shears through the joint. Alternatively, the wall may be located in a preformed slot in the ring beam footing.

In anchored, flexible-base, circular tanks (Type 2.3(1)) it is assumed that the entire base shear is transmitted by membrane (tangential) shear with only insignificant vertical bending.

$Q = 1.0V$, and

$$q_{max} = \frac{Q}{pR} = \frac{V}{pR}$$

In tank Types 2.3(2) and 2.3(3) it is assumed that the base shear is transmitted by friction only. If friction between the wall base and the footing, or between the wall base and the bearing pads, is insufficient to resist the earthquake shear, some form of mechanical restraint such as dowels, galvanized steel cables, or preformed slots may be required.

Failure to provide a means for shear transfer around the circumference may result in sliding of the wall.

When using preformed slots, vertical bending moments induced in the wall by shear should be considered.

The roof-to-wall joint is subject to earthquake shear from the horizontal acceleration of the roof. Where dowels are provided to transfer this shear, the distribution will be the same as shown in Fig. R5.1 with maximum shear given by

$$q_{max} = \frac{0.8P_r}{pR}$$

where P_r is the force from the horizontal acceleration of the roof.

For tanks with roof overhangs, the concrete lip can be designed to withstand the earthquake force. Because the

roof is free to slide on top of the wall, the shear transfer will take place over that portion of the circumference where the lip overhang comes into contact with the wall. Typically, the distribution of forces and wall reactions in circular tanks will be similar to that shown in Fig. R5.2 but reacting on only half of the circumference. The maximum reaction force will be given by:

$$q_{max} = \frac{2.0P_r}{pR}$$

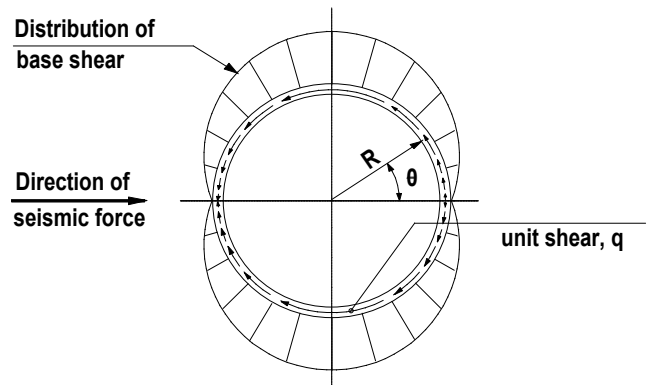

Fig. R5.1—Membrane shear transfer at the base of circular tanks (adapted from Reference 13).

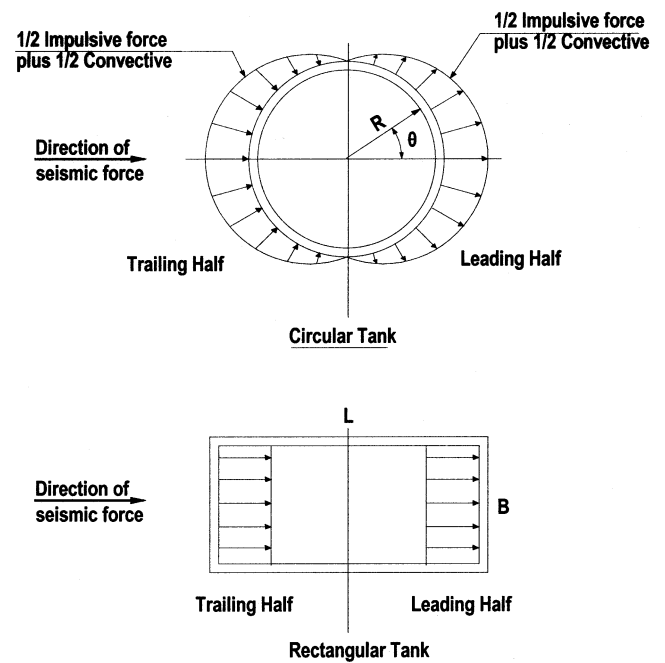

Fig. R5.2—Hydrodynamic pressure distribution in tank walls (adapted from References 3 and 13).

STANDARD

COMMENTARY

5.3—Dynamic force distribution above base

R5.3—Dynamic force distribution above base

5.3.1—Rectangular tanks

R5.3.1—Rectangular tanks

Walls perpendicular to the earthquake force and in the leading half of the tank shall be loaded perpendicular to their plane (dimension *B*) by: (a) the wall's own inertia force P_{wi} ; (b) one-half the impulsive force P_i ; and (c) one-half the convective force P_c .

The vertical distribution, per foot of wall height, of the dynamic forces acting perpendicular to the plane of the wall may be assumed as shown below in Fig. R5.3 (adapted from Reference 13, Section 2.2.9.5), and Fig. R5.4.

Walls perpendicular to the earthquake force and in the trailing half of the tank shall be loaded perpendicular to their plane (dimension *B*) by: (a) the wall's own inertia force P_{wi} ; (b) one-half the impulsive force P_i ; (c) one-half the convective force, P_c ; and (d) the dynamic earth and ground water pressure against the buried portion of the wall.

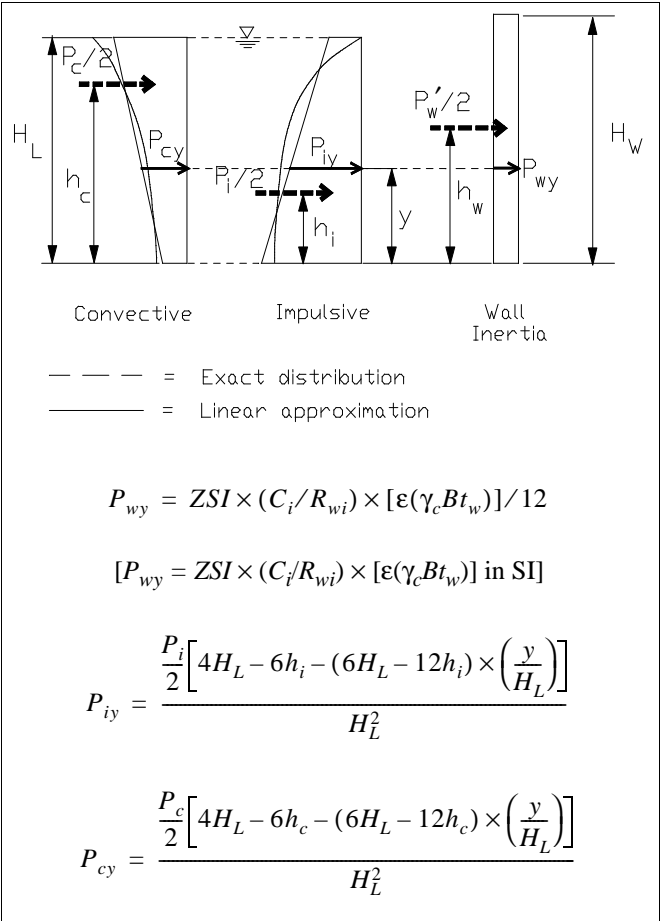

Walls parallel to the direction of the earthquake force shall be loaded in their plane (dimension *L*) by: (a) the wall's own in-plane inertia force P_{wi} ; and (b) the in-plane forces corresponding to the edge reactions from the abutting wall(s).

Figure R5.3—Vertical force distribution: rectangular tanks.

Superimposed on these lateral unbalanced forces shall be the lateral hydrodynamic force resulting from the hydrodynamic pressure due to the effect of vertical acceleration p_{vy} acting on each wall.

The horizontal distribution of the dynamic pressures across the wall width *B*, is

5.3.2—Combining dynamic forces for rectangular tanks

The hydrodynamic force at any given height *y* from the base shall be determined by the following equation

$$P_y = \sqrt{(P_{iy} + P_{wy})^2 + P_{cy}^2 + (p_{vy} \cdot B)^2} \quad (5-1)$$

where applicable, the effect of the dynamic earth and ground water pressures against the buried portion of the walls shall be included.

$$p_{wy} = \frac{P_{wy}}{B} \qquad p_{cy} = \frac{P_{cy}}{B}$$

$$p_{iy} = \frac{P_{iy}}{B} \qquad p_{vy} = \ddot{u}_v q_{hy}$$

It should be noted that the dynamic force on the leading half of the tank will be additive to the hydrostatic force on the wall, and the dynamic force on the trailing half of the tank will reduce the effects of hydrostatic force on the wall.

COMMENTARY

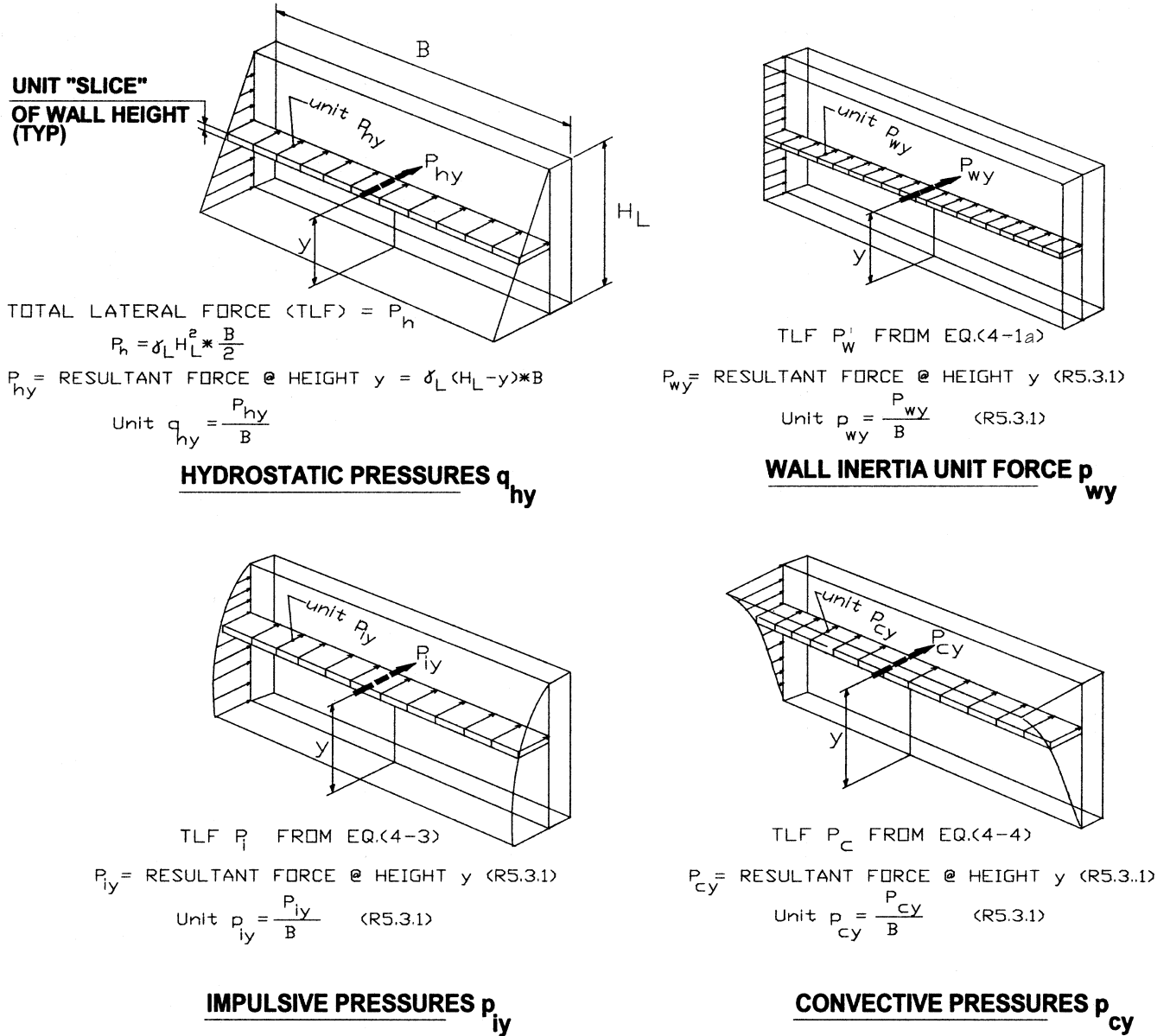

Fig. R5.4—Distribution of hydrostatic and hydrodynamic pressures and inertia forces on the wall of a rectangular liquid-containing structure (adapted from Reference 14).

STANDARD

COMMENTARY

5.3.3—Circular tanks

The cylindrical walls of circular tanks shall be loaded by (a) the wall's own inertia force distributed uniformly around the entire circumference; (b) one-half the impulsive force, P_i applied symmetrical about $q = 0$ and acting outward on one half of the wall, and one-half P_i symmetrically about $q = \pi$ and acting inward on the opposite half of the wall; (c) one-half the convective force, P_c , acting on one-half of the wall symmetrical about $q = 0$ and one-half P_c symmetrical about $q = \pi$ and acting inward on the opposite half of the wall; and (d) the dynamic earth and ground water pressure against the trailing half of the buried portion of the wall.

Superimposed on these lateral unbalanced forces shall be the axisymmetric lateral hydrodynamic force resulting from the hydrodynamic pressure p_{hy} acting on the tank wall.

R5.3.3—Circular tanks

The vertical distribution, per foot of wall height, of the dynamic forces acting on one half of the wall may be assumed as shown below and in Fig. R5.2

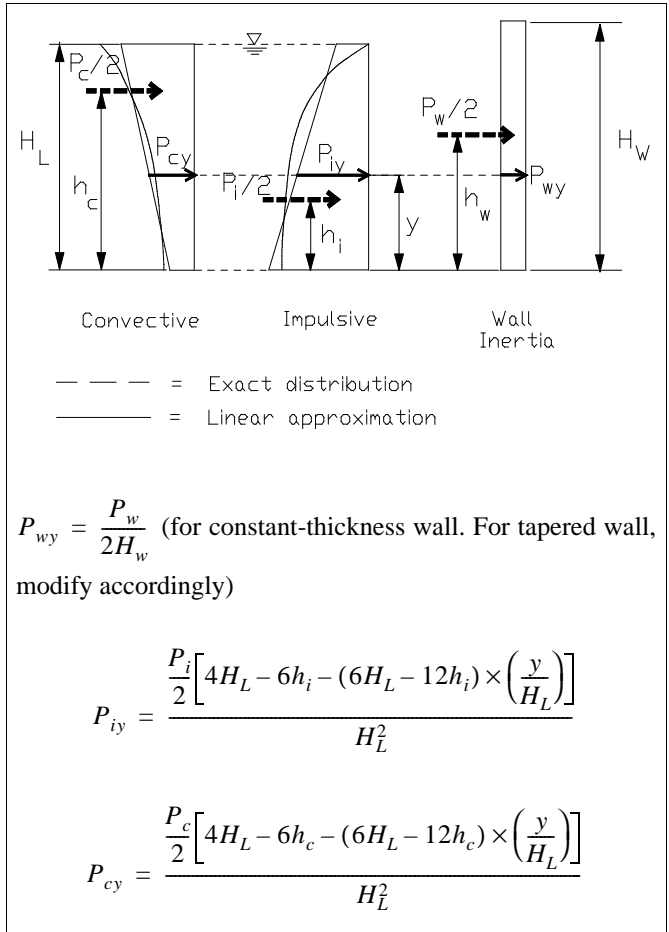

Figure R5.5—Vertical force distribution: circular tanks.

The horizontal distribution of the dynamic pressure across the tank diameter D may be assumed as follows:

$$p_{wy} = \frac{P_{wy}}{pR} \qquad p_{cy} = \frac{16P_{cy}}{9pR} \cdot \cos q$$

$$p_{iy} = \frac{2P_{iy}}{pR} \cdot \cos q \qquad p_{hy} = \ddot{u}_v q_{hy}$$

CHAPTER 6—STRESSES

STANDARD

6.1—Rectangular tanks

The vertical and horizontal bending stresses and shear stresses in the wall and wall base due to lateral earthquake forces shall be computed on the basis of slab action (5.2 and 5.3), using an acceptable pressure distribution.

6.2—Circular tanks

The vertical bending stresses and shear stresses in the wall and wall base due to lateral earthquake forces shall be computed on the basis of shell action using an acceptable pressure distribution.

Hydrodynamic membrane (hoop) forces in the cylindrical wall corresponding to any liquid level, y , above the tank base shall be determined by the following equation

$$N_y = \sqrt{(N_{iy} + N_{wy})^2 + N_{cy}^2 + N_{hy}^2} \quad (6-1)$$

and hoop stress

$$s_y = \frac{N_y}{12t_w} \quad (6-2)$$

$$[s_y = \frac{N_y}{t_w} \text{ in the SI system}]$$

where t_w = wall thickness at the level being investigated (liquid level y).

COMMENTARY

R6—General

In calculating the vertical bending moments in the walls of rectangular and circular tanks, the boundary conditions at the wall-to-base and wall-to-roof joints should be properly accounted for. Typical earthquake force distributions in walls of rectangular and circular tanks are presented in R5.3.1 and R5.3.3 respectively.

R6.2—Circular tanks

For free-base circular tanks (Type 2.3) the terms in Eq. (6-1) are defined as follows

$$N_{iy} = p_{iy}(@q = 0) \cdot R = \frac{2P_{iy}}{p}$$

$$N_{cy} = p_{cy}(@q = 0) \cdot R = \frac{16P_{cy}}{9p}$$

$$N_{hy} = \ddot{u}_v \cdot Q_{hy}$$

$$N_{wy} = p_{wy} \cdot R = \frac{P_{wy}}{p}$$

where

$$Q_{hy} = q_{hy} \cdot R$$

For fixed- or hinged-base circular tanks (Types 2.1 and 2.2), the terms in Eq. (6-1) should be modified to account for the effects of base restraint. Similarly, the terms in Eq. (6-1) should be modified to account for the restraint of rigid wall-to-roof joints.

Notes

CHAPTER 7—FREEBOARD

STANDARD

7.1—Wave oscillation

Provisions shall be made to accommodate the maximum wave oscillation d_{max} , generated by earthquake acceleration.

COMMENTARY

R7.1—Wave oscillation

The horizontal earthquake acceleration causes the contained fluid to slosh with vertical displacement of the fluid surface. The maximum vertical displacement d_{max} may be calculated from the following expressions

$$(a) d_{max} = (L/2) (ZSI \cdot C_c) \text{ rectangular}$$

$$(b) d_{max} = (D/2) (ZSI \cdot C_c) \text{ circular}$$

where C_c is the spectral amplification factor as computed in [Section 9.4](#).

The amount of freeboard required for design will vary. Where overtopping is tolerable, no freeboard provision is necessary. Where loss of liquid should be prevented (for example, tanks for the storage of toxic liquids), or where overtopping may result in scouring of the foundation materials or cause damage to pipes, roof, or both, then one or more of the following measures should be undertaken:

- Provide a freeboard allowance;
- Design the roof structure to resist the resulting uplift pressures; and
- Provide an overflow spillway.

Where site-specific response spectra are used, the maximum vertical displacement d_{max} may be calculated from the following expressions

$$(a) d_{max} = (L/2)IA_c = (L/2)I \cdot h_c \frac{S_D}{g} \left(\frac{2p}{T_c}\right)^2$$

rectangular

$$(b) d_{max} = (D/2)IA_c = (D/2)I \cdot h_c \frac{S_D}{g} \left(\frac{2p}{T_c}\right)^2$$

circular

where A_c , h_c , and S_D are as defined in [R4.2.2](#).

Notes

CHAPTER 8—EARTHQUAKE-INDUCED EARTH PRESSURES

STANDARD

COMMENTARY

8.1—General

Dynamic earth pressures shall be taken into account when computing the base shear of a partially or fully buried liquid-containing structure and when designing the walls.

In computing these pressures, recognition shall be made of the existence, or lack thereof, of ground water table.

K_o , the coefficient of lateral earth pressure at rest, shall be used in estimating the earth pressures, unless it is demonstrated by calculation that the structure deflects sufficiently to lower the coefficient to some value between K_o and K_a , the active coefficient of lateral earth pressure.

In a pseudo-static analysis: (1) the resultant of the seismic component of the earth pressure shall be assumed to act at a point 0.6 of the earth height above the base; and (2) when part or all of the structure is below the water table, the resultant of the incremental increase in water pressure shall be assumed to act at a point 1/3 of the water depth above the base.

8.2—Limitations

In a buried tank, the dynamic backfill forces shall not be relied upon to reduce the dynamic effects of the stored liquid or vice versa.

8.3—Alternative methods

The provisions of this chapter shall be permitted to be superseded by recommendations of the project geotechnical engineer that are approved by the building official having jurisdiction.

Notes

CHAPTER 9—DYNAMIC MODEL

STANDARD

9.1—General

The dynamic characteristics of ground-supported liquid-containing structures subjected to earthquake acceleration shall be computed in accordance with 9.2, 9.3 and 9.5.

The dynamic characteristics of pedestal-mounted liquid-containing structures shall be computed in accordance with 9.6.

9.2—Rectangular tanks (Type 1)

9.2.1—Equivalent masses of accelerating liquid (Fig. 9.2)

$$\frac{W_i}{W_L} = \frac{\tanh[0.866(L \div H_L)]}{0.866(L \div H_L)} \quad (9-1)$$

$$\frac{W_c}{W_L} = 0.264(L \div H_L) \tanh[3.16(H_L \div L)] \quad (9-2)$$

9.2.2—Height to centers of gravity (excluding base pressure, EBP [Fig. 9.3])

For tanks with $\frac{L}{H_L} < 1.333$,

$$\frac{h_i}{H_L} = 0.5 - 0.09375\left(\frac{L}{H_L}\right) \quad (9-3)$$

For tanks with $\frac{L}{H_L} \geq 1.333$,

$$\frac{h_i}{H_L} = 0.375 \quad (9-4)$$

For all tanks,

$$\frac{h_c}{H_L} = 1 - \frac{\cosh[3.16(H_L \div L)] - 1}{3.16(H_L \div L) \sinh[3.16(H_L \div L)]} \quad (9-5)$$

9.2.3—Heights to center of gravity (including base pressure, IBP [Fig. 9.4])

For tanks with $\frac{L}{H_L} < 0.75$,

COMMENTARY

R9.1—General

The following commentary is adapted from Reference 3:

The design procedures described in Chapter 4 recognize that the seismic analysis of liquid-containing structures subjected to a horizontal acceleration should include the inertia forces generated by the acceleration of the structure itself; and the hydrodynamic forces generated by the horizontal acceleration of the contained liquid.

Figure R9.1 shows an equivalent dynamic model for calculating the resultant seismic forces acting on a ground-based fluid container with rigid walls. This model has been accepted by the profession for the past 30 years. In this model, W_i represents the resultant effect of the impulsive seismic pressures on the tank walls. W_c represents the resultant of the sloshing fluid pressures.

In the model, W_i is rigidly fastened to the tank walls at a height h_i above the tank bottom, that corresponds to the location of the resultant impulsive force P_i . W_i moves with the tank walls as they respond to the ground shaking (the fluid is assumed to be incompressible). The impulsive pressures are generated by the seismic accelerations of the tank walls so that the force P_i is evenly divided into a pressure force on the wall accelerating into the fluid, and a suction force on the wall accelerating away from the fluid. During an earthquake, the force P_i changes direction several times per second, corresponding to the change in direction of the base acceleration; the overturning moment generated by P_i is thus frequently ineffective in tending to overturn the tank.

W_c is the equivalent mass of the oscillating fluid that produces the convective pressures on the tank walls with resultant force P_c , which acts at a height of h_c above the tank bottom. In the model, W_c is fastened to the tank walls by springs that produce a period of vibration corresponding to the period of fluid sloshing. The sloshing pressures on the tank walls result from the fluid motion associated with the wave oscillation. The period of oscillation of the sloshing depends upon the ratio of fluid depth to tank diameter and is usually several seconds. The overturning moment exerted by P_c (Fig. R9.1) acts for a sufficient time to tend to uplift the tank wall if there is insufficient restraining weight. The forces P_i and P_c act independently and simultaneously on the tank. The force P_i (and its associated pressures) primarily act to stress the tank wall, whereas P_c acts primarily to uplift the tank wall. The vertical vibrations of the ground are also transmitted to the fluid, thus producing pressures that act on the tank walls. They act to increase or decrease the hoop stresses.

STANDARD

$$\frac{h_i \zeta}{H_L} = 0.45 \quad (9-6)$$

For tanks with $\frac{L}{H_L} \approx 0.75$,

$$\frac{h_i \zeta}{H_L} = \frac{0.866 \left(\frac{L}{H_L} \right)}{2 \cdot \tanh \left[0.866 \left(\frac{L}{H_L} \right) \right]} - \frac{1}{8} \quad (9-7)$$

For all tanks,

$$\frac{h_c \zeta}{H_L} = 1 - \frac{\cosh \left[3.16 \left(\frac{H_L}{L} \right) \right] - 2.01}{3.16 \left(\frac{H_L}{L} \right) \cdot \sinh \left[3.16 \left(\frac{H_L}{L} \right) \right]} \quad (9-8)$$

9.2.4—Dynamic properties

The structural stiffness k shall be computed on the basis of correct boundary conditions.

$$w_i = \sqrt{\frac{k}{m}} \quad (9-9)$$

$$m = m_w + m_i \quad (9-10)$$

$$T_i = \frac{2p}{w_i} = 2p \sqrt{\frac{m}{k}} \quad (9-11)$$

$$w_c = \frac{1}{\sqrt{L}} \quad (9-12)$$

where

$$l = \sqrt{3.16 g \tanh [3.16 (H_L \approx L)]} \quad (9-13)$$

$$T_c = \frac{2p}{w_c} = \left(\frac{2p}{l} \right) \sqrt{L} \quad (9-14)$$

$$\left[\left(\frac{2p}{l} \right) \text{ from Fig. 9.5} \right]$$

9.3—Circular tanks (Type 2)

9.3.1—Equivalent masses of accelerating liquid (Fig. 9.6)

COMMENTARY

The pressures and forces on a cylindrical tank are similar to, but not the same as, those acting on a rectangular tank.

The rapid fluctuations of the force P_i mean that the bending moments and stresses in the wall of a rectangular tank also vary rapidly (the effect is not like a constant force acting on the wall). The duration of the fluctuations is 10 to 15 s for earthquakes of magnitude 6.5 to 7.5.

The force P_c fluctuates sinusoidally with a period of vibration that depends on the dimensions of the tank and can be several seconds or longer. The duration of sloshing can be 20 to 40 s for earthquakes of magnitude 6.5 to 7.5. Note that the damping of the sloshing water is small, approximately 0.5% to 1% of critical damping. The sloshing increases and decreases the fluid pressure on the wall. Normally this is smaller than the impulsive effect, but if there is not enough dead load, the tank will tend to uplift.

R9.2.4—Dynamic properties

The following equations are provided as examples for the special case of a wall of uniform thickness,

$$m_w = H_w \cdot \frac{t_w}{12} \cdot r_c$$

$$[m_w = H_w \cdot \frac{t_w}{10^3} \cdot r_c \text{ in the SI system}]$$

$$m_i = \left(\frac{W_i}{W_L} \right) \cdot \left(\frac{L}{2} \right) \cdot H_L \cdot r_L$$

$$h = \frac{(h_w m_w + h_i m_i)}{(m_w + m_i)}$$

where $h_w = 0.5H_w$ and h_i is obtained from Eq. (9-3) and (9-4), and Fig. 9.3.

For walls of nonuniform thickness, special analysis is required to determine m_w , m_i , and h .

For fixed-base, open-top tanks, flexural stiffness k may be computed using the following equation from Reference 13:

$$k = \frac{E_c}{48} \cdot \left(\frac{t_w}{h} \right)^3$$

$$[k = \frac{E_c}{4 \cdot 10^6} \cdot \left(\frac{t_w}{h} \right)^3 \text{ in the SI system}]$$

STANDARD

$$\frac{W_i}{W_L} = \frac{\tanh[0.866(D \mp H_L)]}{0.866(D \mp H_L)} \quad (9-15)$$

$$\frac{W_c}{W_L} = 0.230(D \mp H_L) \tanh[3.68(H_L \mp D)] \quad (9-16)$$

9.3.2—Heights to centers of gravity (excluding base pressure, EBP [Fig. 9.7])

For tanks with $\frac{D}{H_L} < 1.333$,

$$\frac{h_i}{H_L} = 0.5 - 0.09375\left(\frac{D}{H_L}\right) \quad (9-17)$$

For tanks with $\frac{L}{H_L} \geq 1.333$,

$$\frac{h_i}{H_L} = 0.375 \quad (9-18)$$

For all tanks,

$$\frac{h_c}{H_L} = 1 - \frac{\cosh\left[3.68\left(\frac{H_L}{D}\right)\right] - 1}{3.68\left(\frac{H_L}{D}\right) \cdot \sinh\left[3.68\left(\frac{H_L}{D}\right)\right]} \quad (9-19)$$

9.3.3—Heights to centers of gravity [including base pressure, EBP (Fig. 9.8)]

For tanks with $\frac{D}{H_L} < 0.75$,

$$\frac{h_i \zeta}{H_L} = 0.45 \quad (9-20)$$

For tanks with $\frac{D}{H_L} \geq 0.75$,

$$\frac{h_i \zeta}{H_L} = \frac{0.866\left(\frac{D}{H_L}\right)}{2 \cdot \tanh\left[0.866\left(\frac{D}{H_L}\right)\right]} - \frac{1}{8} \quad (9-21)$$

For all tanks,

$$\frac{h_c \zeta}{H_L} = 1 - \frac{\cosh\left[3.68\left(\frac{H_L}{D}\right)\right] - 2.01}{3.68\left(\frac{H_L}{D}\right) \cdot \sinh\left[3.68\left(\frac{H_L}{D}\right)\right]} \quad (9-22)$$

COMMENTARY

As an alternative to computing the natural period of vibration, Eq. (9-31) may be conservatively used to calculate the impulsive forces regardless of the actual boundary conditions of the structure or structural components being analyzed.

STANDARD

COMMENTARY

9.3.4—Dynamic properties

R9.3.4—Dynamic properties

 T_i :

For tank Types 2.1 and 2.2:

$$w_i = C_i \cdot \frac{12}{H_L} \sqrt{\frac{E_c}{r_c}} \quad (9-23)$$

$$[w_i = C_i \cdot \frac{1}{H_L} \sqrt{\frac{10^3 E_c}{r_c}} \text{ in the SI system}]$$

$$C_i = C_w \cdot 10 \sqrt{\frac{t_w}{12R}} \quad (9-24)$$

[C_w from Fig. 9.10]

$$[C_i = C_w \cdot \sqrt{\frac{t_w}{10R}} \text{ in the SI system}]$$

$$T_i = \frac{2p}{w_i} \quad (9-25)$$

For tank Type 2.3:

$$T_i = \sqrt{\frac{8p(W_w + W_r + W_i)}{gDk_a}} \quad (9-26)$$

but shall not exceed 1.25 s.

$$k_a = 144 \left[\left(\frac{A_s E_s \cos^2 a}{L_s S_s} \right) + \left(\frac{2G_p w_p L_p}{t_p S_p} \right) \right] \quad (9-27)$$

$$[k_a = 10^3 \left[\left(\frac{A_s E_s \cos^2 a}{L_s S_s} \right) + \left(\frac{2G_p w_p L_p}{t_p S_p} \right) \right] \text{ in the SI system}]$$

$$w_c = \frac{1}{\sqrt{D}} \quad (9-28)$$

where

$$l = \sqrt{3.68g \tanh[3.68(H_L \sqrt{D})]} \quad (9-29)$$

$$T_c = \frac{2p}{w_c} = \left(\frac{2p}{l} \right) \sqrt{D} \quad (9-30)$$

$$\left[\left(\frac{2p}{l} \right) \text{ from Fig. 9.9} \right]$$

Equations (9-23) and (9-24) are adapted from References 15 and 16.

Equations (9-26) and (9-27) are adapted from References 17 and 18.

Equations (9-13), (9-14), (9-29), and (9-30) are adapted from Reference 3.

9.4—Spectral amplification factors C_i and C_c

C_i shall be determined as follows

For $T_i \leq 0.31$ s,

$$C_i = \frac{2.75}{S} \quad (9-31)$$

For $T_i > 0.31$ s,

$$C_i = \frac{1.25}{T_i^{2/3}} \leq \frac{2.75}{S} \quad (9-32)$$

C_c shall be determined as follows

For $T_c \geq 2.4$ s,

$$C_c = \frac{6.0}{T_c^2} \quad (9-33)$$

9.5—Effective mass coefficient e

9.5.1—Rectangular tanks

$$e = \left[0.0151 \left(\frac{L}{H_L} \right)^2 - 0.1908 \left(\frac{L}{H_L} \right) + 1.021 \right] \leq 1.0 \quad (9-34)$$

9.5.2—Circular tanks

$$e = \left[0.0151 \left(\frac{D}{H_L} \right)^2 - 0.1908 \left(\frac{D}{H_L} \right) + 1.021 \right] \leq 1.0 \quad (9-35)$$

9.6—Pedestal-mounted tanks

The equivalent masses, W_i and W_c , and heights to the centers of gravity h_i , h_c , h_i^c , and h_c^c of a mounted tank, shall be computed using the corresponding equations of 9.2 and 9.3 for rectangular and circular tanks, respectively.

The dynamic properties, including periods of vibration and lateral coefficients, shall be permitted to be determined on the basis of generally acceptable methods of dynamic analysis.

R9.4—Spectral amplification factors C_i and C_c

In practice, T_c will usually be greater than 2.4 s. In situations where $T_c < 2.4$ s, C_c may be approximated using the equation

$$C_c = 1.5 \cdot \frac{1.25}{T_c^{2/3}} = \frac{1.875}{T_c^{2/3}} \leq \frac{2.75}{S}$$

C_i or C_c may be conservatively taken as $2.75/S$ for any tank.

R9.5—Effective mass coefficient e

The coefficient e represents the ratio of the equivalent (or generalized) dynamic mass of the tank shell to its actual total mass. Equations (9-34) and (9-35) are adapted from [Reference 15](#).

For additional information related to the effective mass coefficient, see [Reference 16](#).

R9.6—Pedestal-mounted tanks

[References 3](#) and [19](#) provide additional guidelines on the dynamic analysis of pedestal-mounted tanks.

COMMENTARY

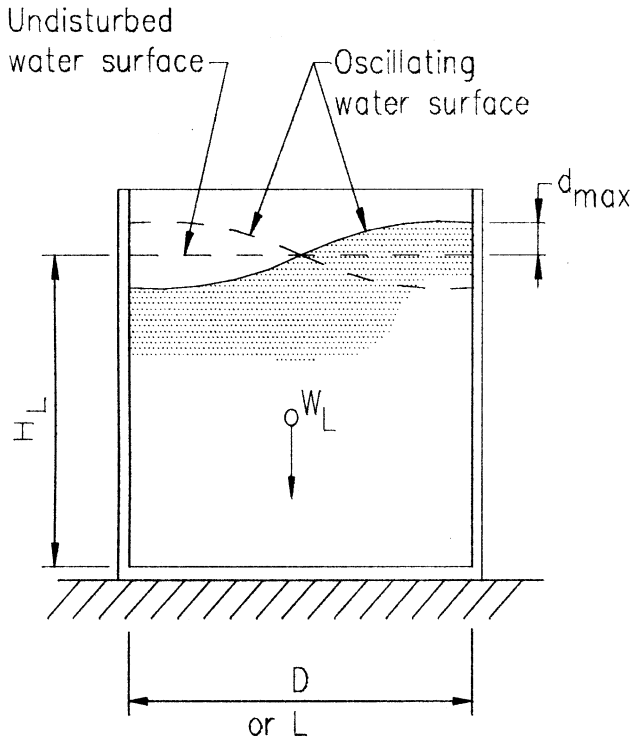

(a) Fluid Motion in Tank

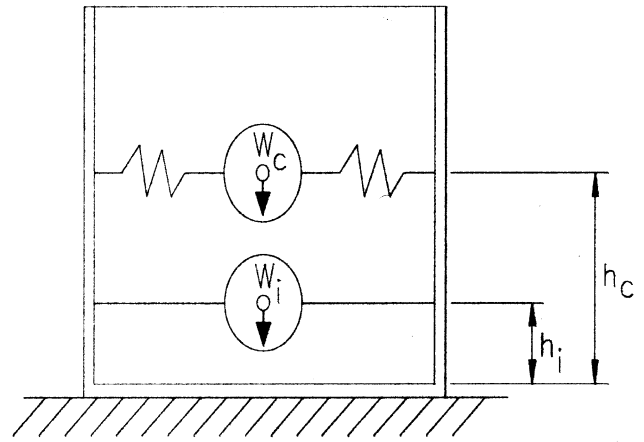

(b) Dynamic Model

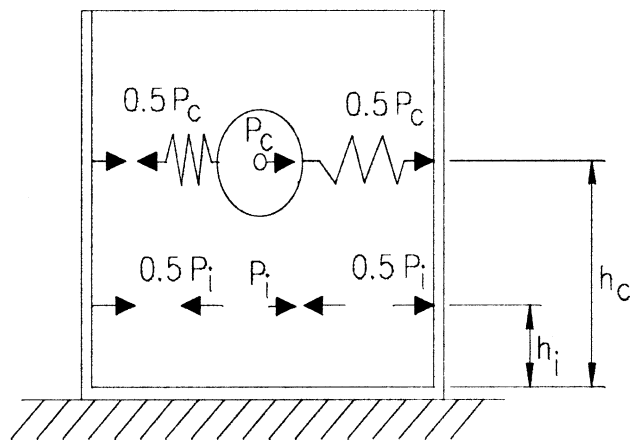

$$P_i + P_c$$

$$M_i + M_c = P_i h_i + P_c h_c$$

(c) Dynamic Equilibrium of Horizontal Forces

Fig. R9.1—Dynamic model of liquid-containing tank rigidly supported on the ground (adapted from References 3 and 4).

IMPULSIVE AND CONVECTIVE MASS FACTORS vs. L/H_L RATIO

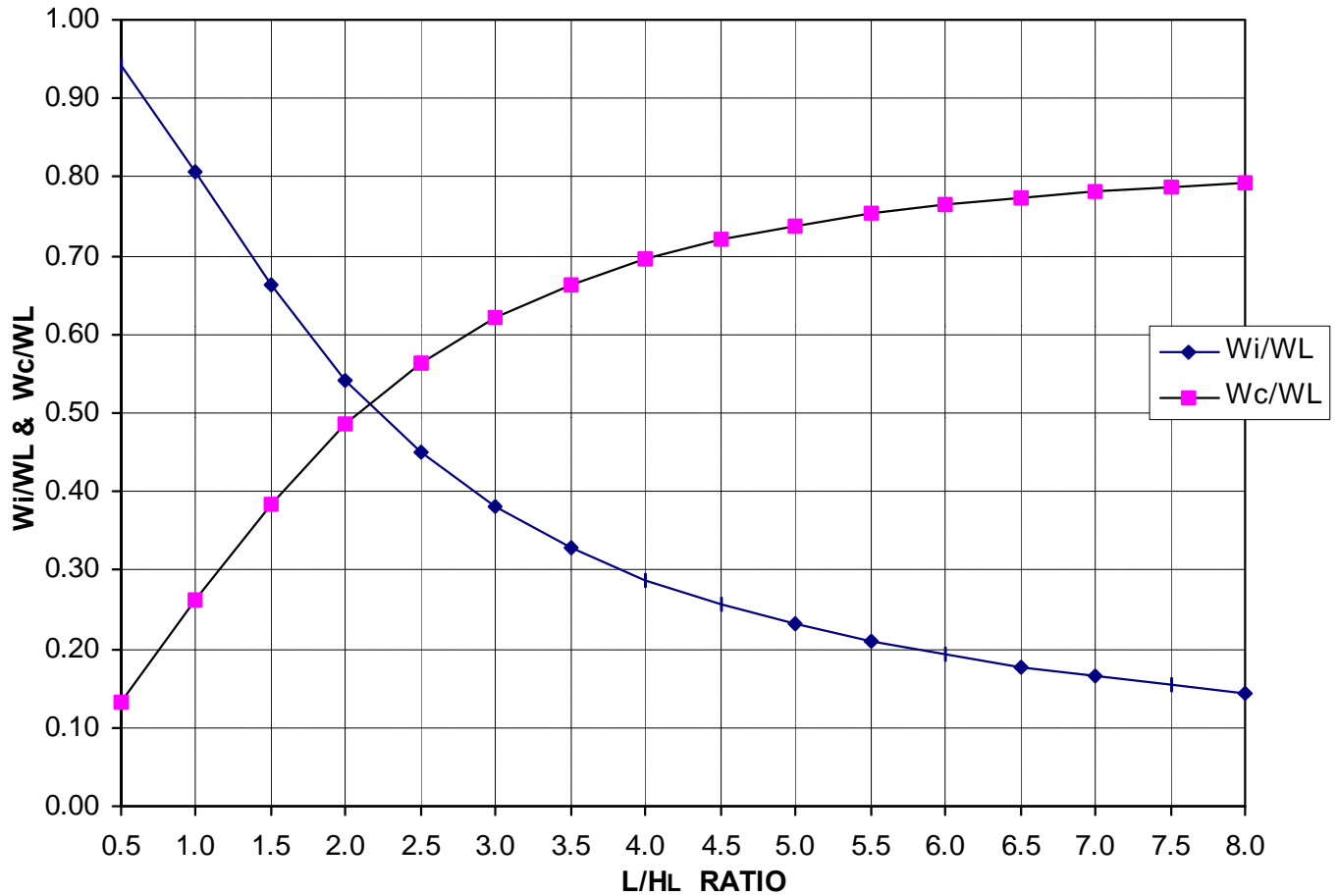

Fig. 9.2—Factors W_i/W_L and W_c/W_L versus ratio L/H_L for rectangular tanks.

$$\frac{W_i}{W_L} = \frac{\tanh[0.866(L \div H_L)]}{0.866(L \div H_L)} \quad (9-1)$$

$$\frac{W_c}{W_L} = 0.264(L \div H_L) \tanh[3.16(H_L \div L)] \quad (9-2)$$

STANDARD

IMPULSIVE AND CONVECTIVE HEIGHT FACTORS vs. L/H_L RATIO

Fig. 9.3—Factors h_i/H_L and h_c/H_L versus ratio L/H_L for rectangular tanks (EBP).

h_i/H_L :

$$\text{For tanks with } \frac{L}{H_L} < 1.333 : \quad \frac{h_i}{H_L} = 0.5 - 0.09375 \left(\frac{L}{H_L} \right) \quad (9-3)$$

$$\text{For tanks with } \frac{L}{H_L} \geq 1.333 : \quad \frac{h_i}{H_L} = 0.375 \quad (9-4)$$

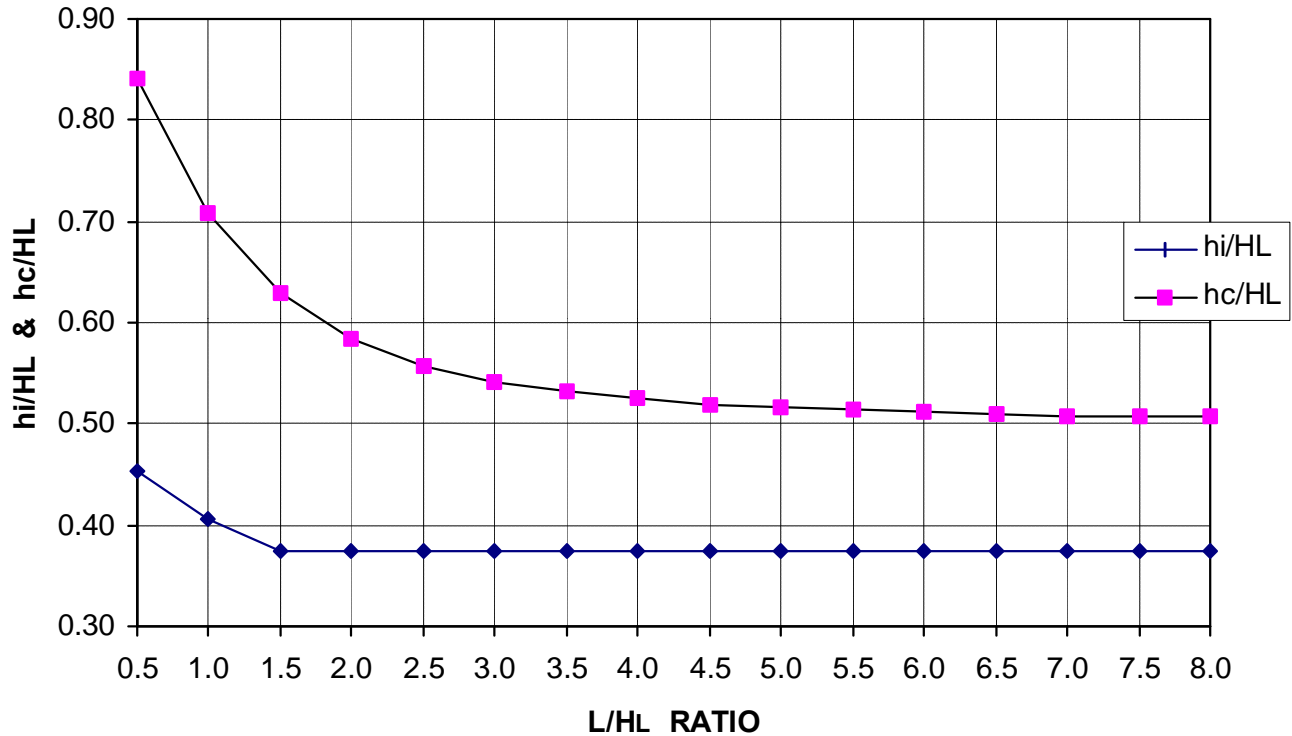
For all tanks:

$$\frac{h_c}{H_L} = 1 - \frac{\cosh[3.16(H_L \mp L) - 1]}{3.16(H_L \mp L) \sinh[3.16(H_L \mp L)]} \quad (9-5)$$

STANDARD

IMPULSIVE AND CONVECTIVE HEIGHT FACTORS vs. L/H_L RATIO

Fig. 9.4—Factors h_i/H_L and h_c/H_L versus ratio L/H_L for rectangular tanks (IBP).

h_i/H_L :

$$\text{For tanks with } \frac{L}{H_L} < 0.75 : \quad \frac{h_i}{H_L} = 0.45 \quad (9-6)$$

$$\text{For tanks with } \frac{L}{H_L} \geq 0.75 : \quad \frac{h_i}{H_L} = \frac{0.866\left(\frac{L}{H_L}\right)}{2 + \tanh\left[0.866\left(\frac{L}{H_L}\right)\right]} - \frac{1}{8} \quad (9-7)$$

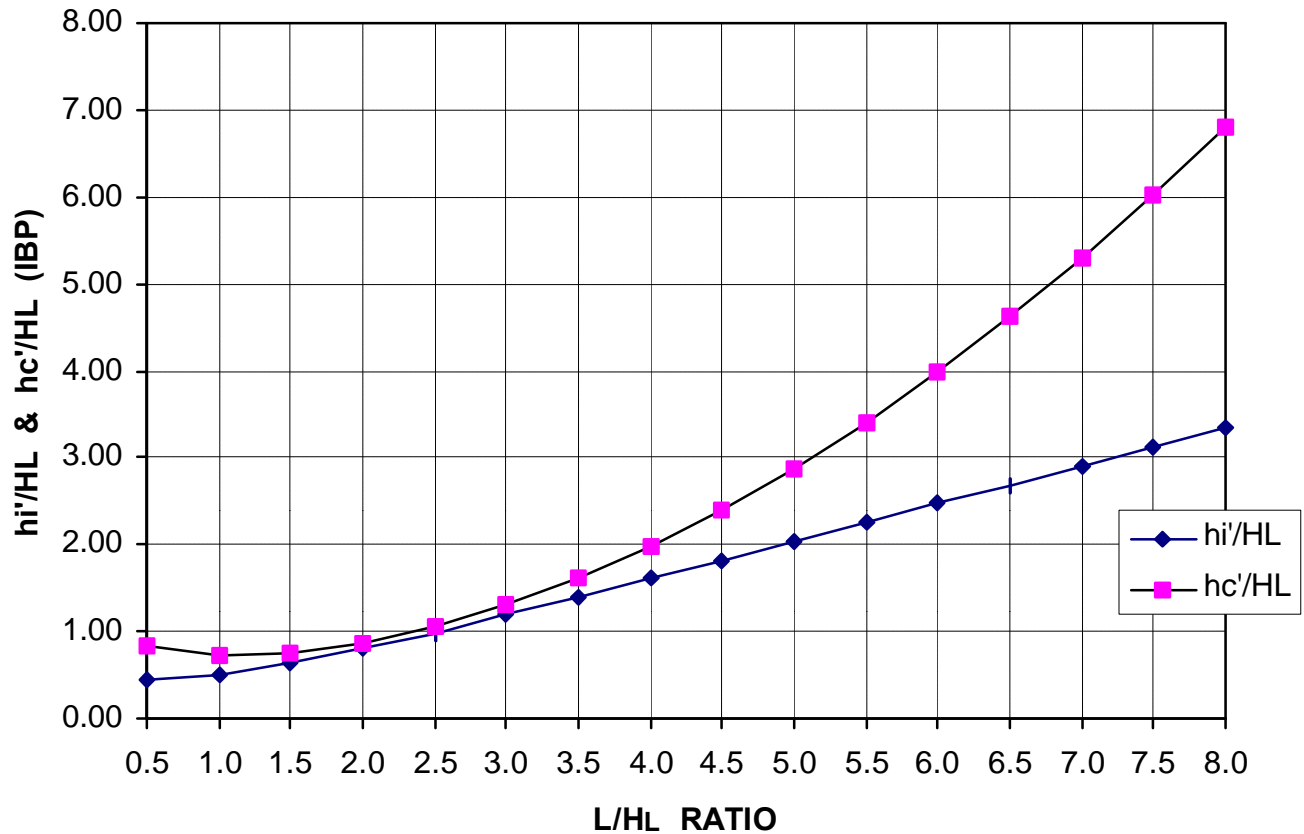
For all tanks:

$$\frac{h_c}{H_L} = 1 - \frac{\cosh\left[3.16\left(\frac{H_L}{L}\right)\right] - 2.01}{3.16\left(\frac{H_L}{L}\right) + \sinh\left[3.16\left(\frac{H_L}{L}\right)\right]} \quad (9-8)$$

STANDARD

FACTOR (2p/l)

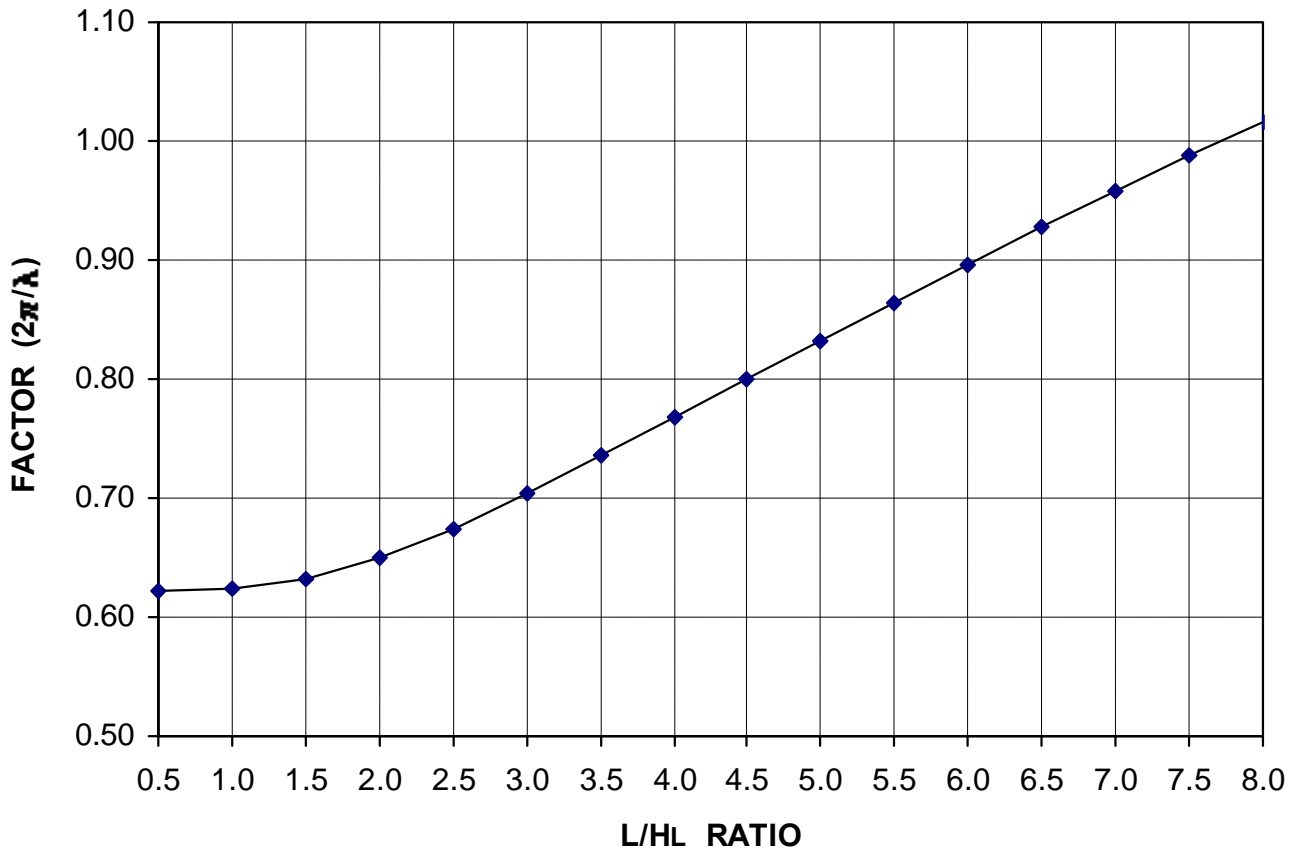

Fig. 9.5—Factor 2p/l for rectangular tanks.

$$w_c = \frac{1}{\sqrt{L}} \tag{9-12}$$

$$l = \sqrt{3.16g \tanh[3.16(H_L \sqrt{L})]} \tag{9-13}$$

$$T_c = \frac{2p}{w_c} = \left(\frac{2p}{l}\right)\sqrt{L} \tag{9-14}$$

IMPULSIVE AND CONVECTIVE MASS FACTORS vs. D/H_L RATIO

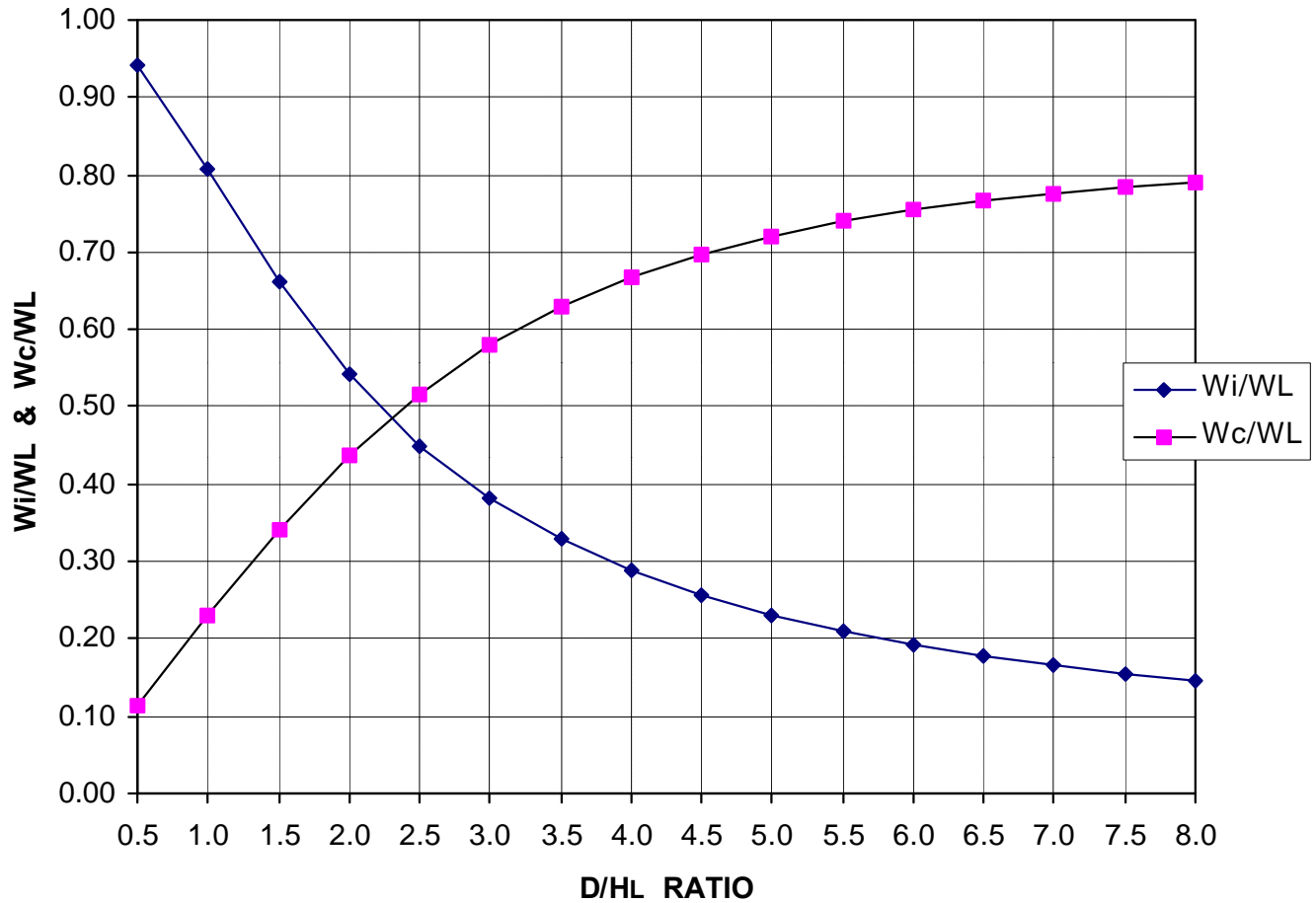

Fig. 9.6—Factors W_i/W_L and W_c/W_L versus ratio D/H_L for circular tanks.

$$\frac{W_i}{W_L} = \frac{\tanh[0.866(D \times H_L)]}{0.866(D \times H_L)} \quad (9-15)$$

$$\frac{W_c}{W_L} = 0.230(D \times H_L) \tanh[3.68(H_L \times D)] \quad (9-16)$$

STANDARD

IMPULSIVE AND CONVECTIVE HEIGHT FACTORS vs. D/H_L RATIO

Fig. 9.7—Factors h_i/H_L and h_c/H_L versus ratio D/H_L for circular tanks (EBP).

h_i/H_L :

$$\text{For tanks with } \frac{D}{H_L} < 1.333: \quad \frac{h_i}{H_L} = 0.5 - 0.09375\left(\frac{D}{H_L}\right) \quad (9-17)$$

$$\text{For tanks with } \frac{D}{H_L} \geq 1.333: \quad \frac{h_i}{H_L} = 0.375 \quad (9-18)$$

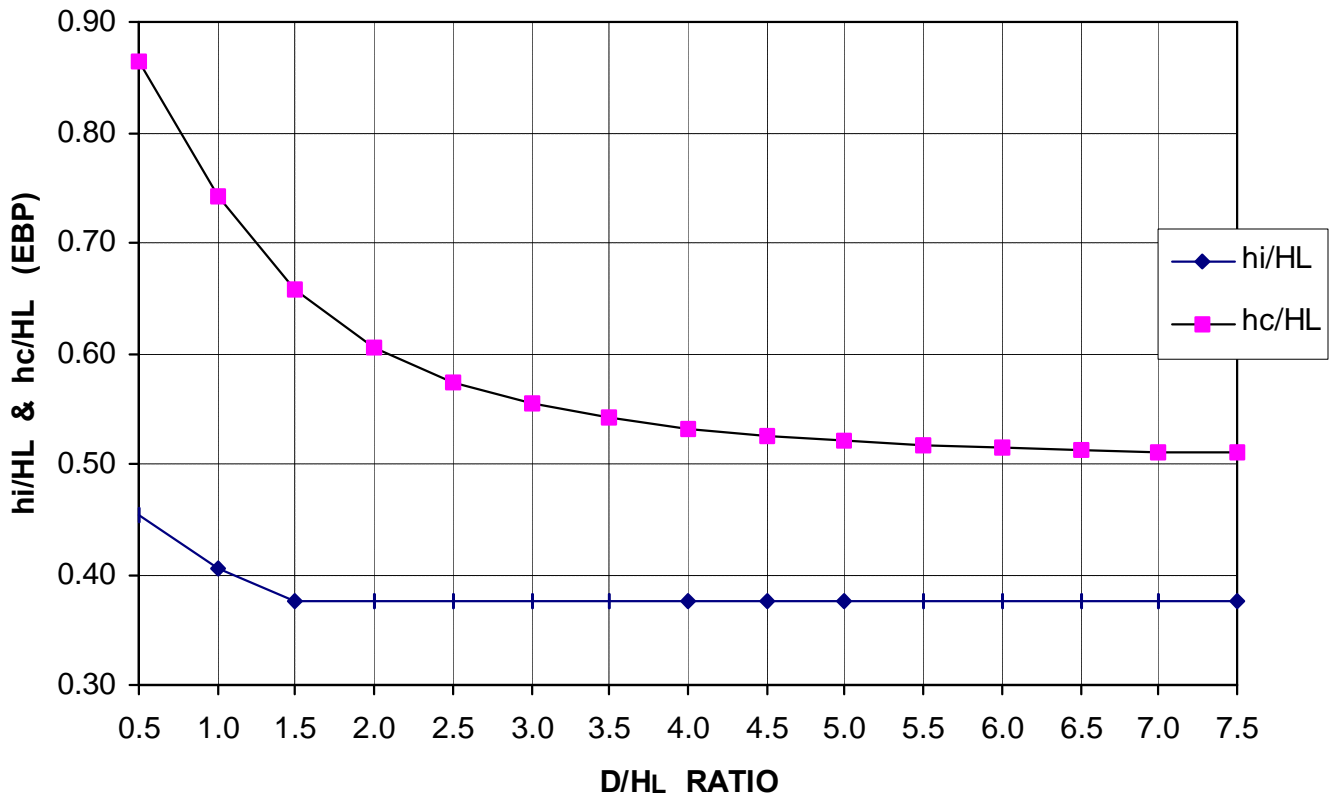
For all tanks:

$$\frac{h_c}{H_L} = 1 - \frac{\cosh\left[3.68\left(\frac{H_L}{D}\right)\right] - 1}{3.68\left(\frac{H_L}{D}\right) \cdot \sinh\left[3.68\left(\frac{H_L}{D}\right)\right]} \quad (9-19)$$

IMPULSIVE AND CONVECTIVE HEIGHT FACTORS vs. D/H_L RATIO

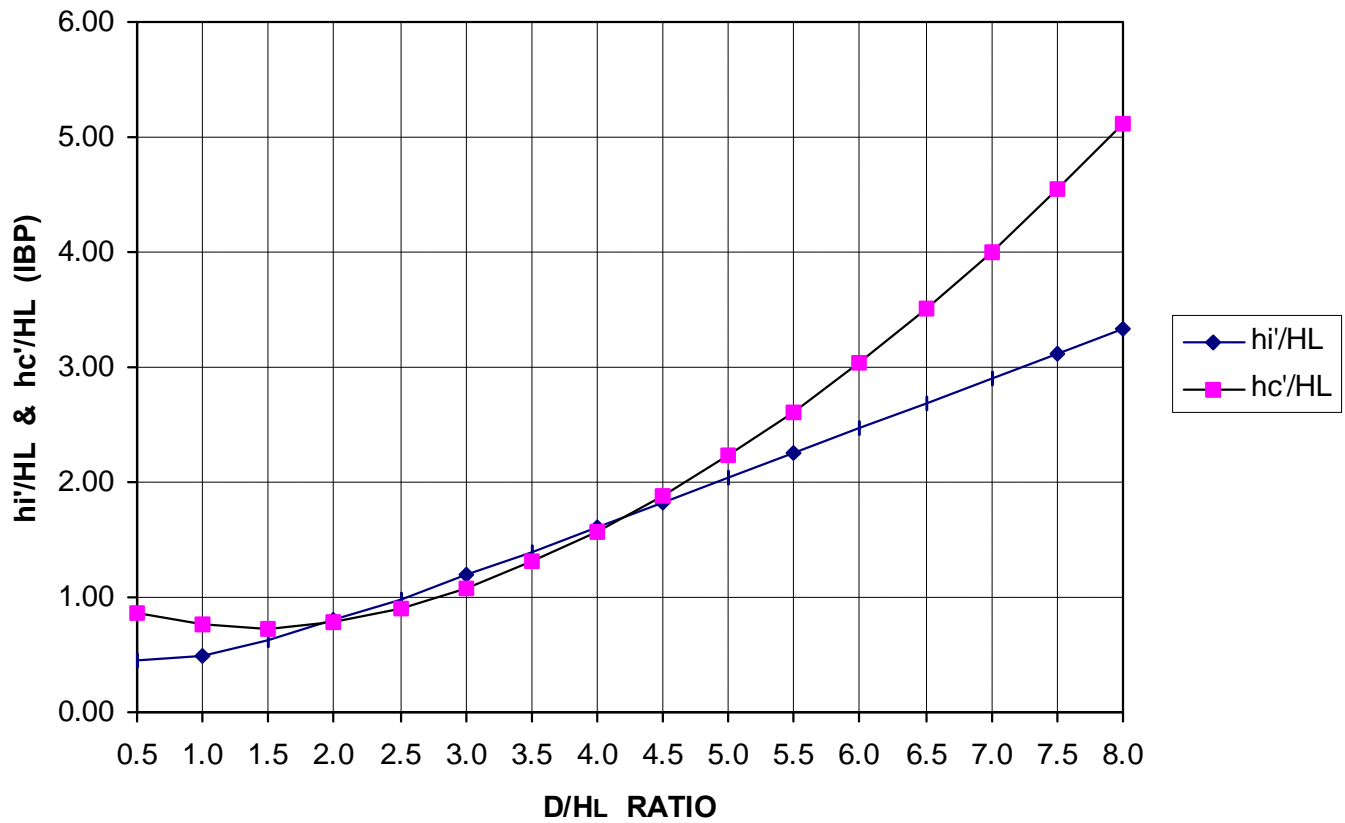

Fig. 9.8—Factors h_i'/H_L and h_c'/H_L versus ratio D/H_L for circular tanks (IBP).

h_i'/H_L :

For tanks with $\frac{D}{H_L} < 0.75$: $\frac{h_i'}{H_L} = 0.45$ (9-20)

For tanks with $\frac{D}{H_L} \geq 0.75$: $\frac{h_i'}{H_L} = \frac{0.866\left(\frac{D}{H_L}\right)}{2 \cdot \tanh\left[0.866\left(\frac{D}{H_L}\right)\right]} - \frac{1}{8}$ (9-21)

For all tanks:

$$\frac{h_c'}{H_L} = 1 - \frac{\cosh\left[3.68\left(\frac{H_L}{D}\right)\right] - 2.01}{3.68\left(\frac{H_L}{D}\right) \cdot \sinh\left[3.68\left(\frac{H_L}{D}\right)\right]} \quad (9-22)$$

STANDARD

FACTOR ($2p/l$)

Fig. 9.9—Factor $2p/l$ for circular tanks.

$$w_c = \frac{1}{\sqrt{D}} \quad (9-28)$$

where

$$l = \sqrt{3.68g \tanh[3.68(H_L \pi D)]} \quad (9-29)$$

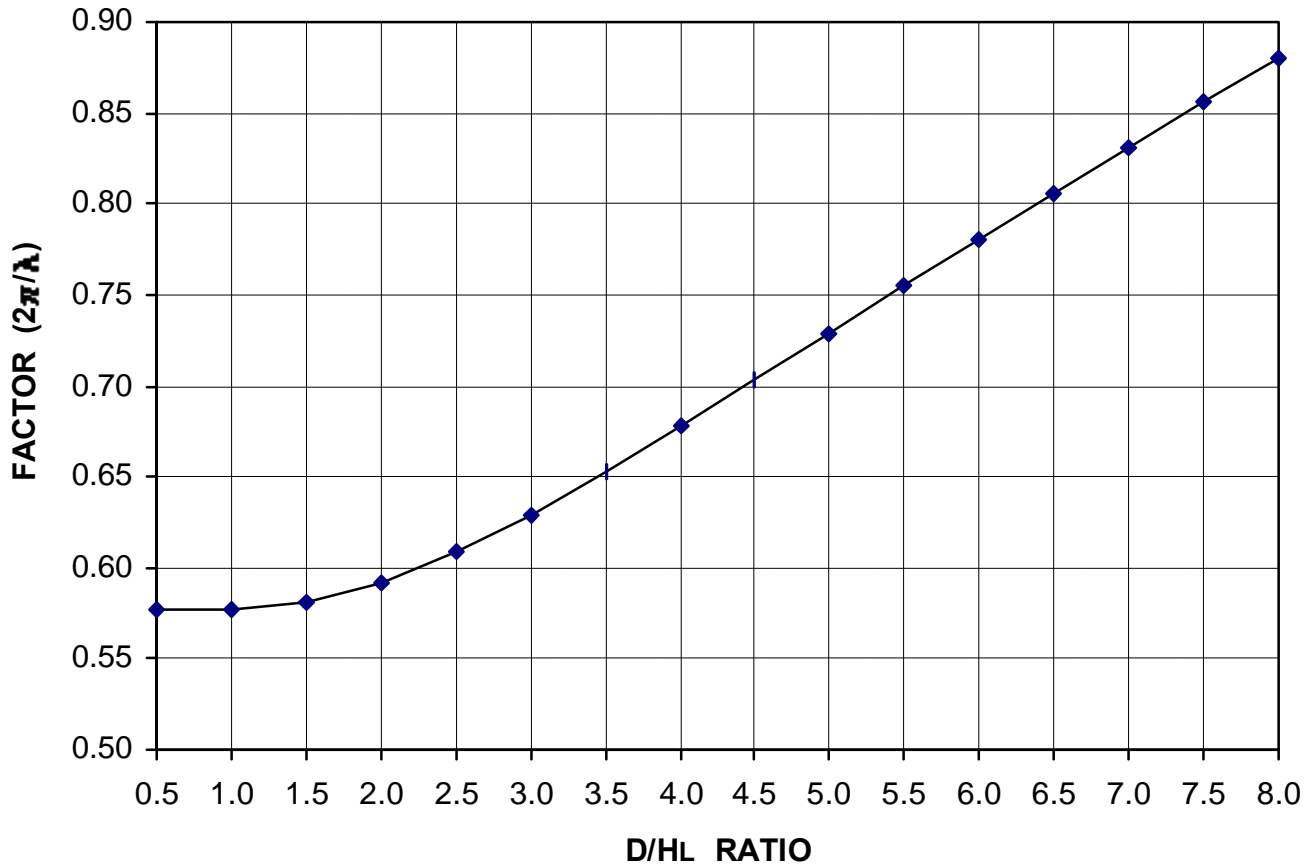
$$T_c = \frac{2p}{w_c} = \left(\frac{2p}{l}\right) \sqrt{D} \quad (9-30)$$

STANDARD

COEFFICIENT C_w 

Fig. 9.10—Coefficient C_w for circular tanks.

For $D/H_L > 0.667$:

$$C_w = 9.375 \cdot 10^{-2} + 0.2039 \left(\frac{H_L}{D} \right) - 0.1034 \left(\frac{H_L}{D} \right)^2 - 0.1253 \left(\frac{H_L}{D} \right)^3 + 0.1267 \left(\frac{H_L}{D} \right)^4 - 3.186 \cdot 10^{-2} \left(\frac{H_L}{D} \right)^5$$

Notes

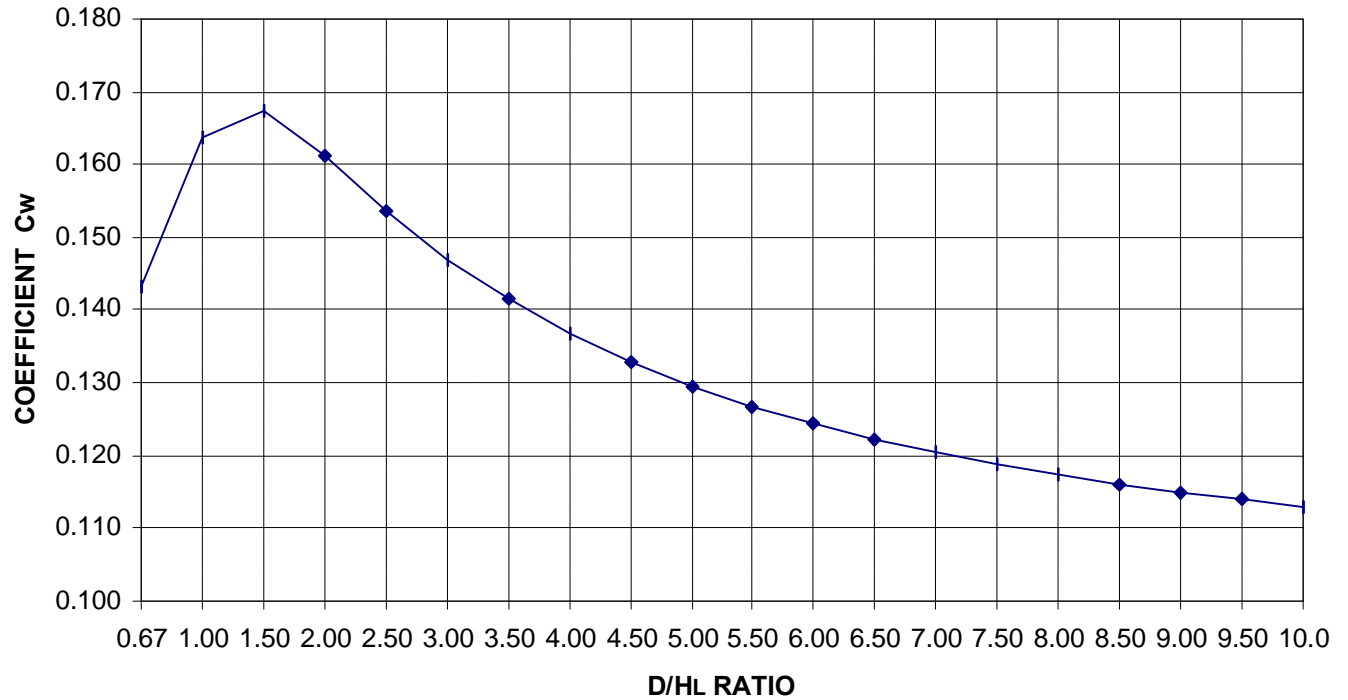
CHAPTER 10—COMMENTARY REFERENCES

1. ACI Committee 350, "Code Requirements for Environmental Engineering Concrete Structures (ACI 350-01) and Commentary (350R-01)," American Concrete Institute, Farmington Hills, Mich., 2001.
2. "Earthquake Design Criteria for Water Supply & Wastewater Systems," *National Science Foundation Report NSF/CE52-81079*, Sept. 1981.
3. Housner, G. W., "Dynamic Pressure on Fluid Containers," *Technical Information (TID) Document 7024*, Chapter 6, and Appendix F, U.S. Atomic Energy Commission, 1963.
4. American Society of Civil Engineering, "Fluid/Structure Interaction During Seismic Excitation," *Report by the Committee on Seismic Analysis*, 1984
5. Housner, G. W., "Limit Design of Structures to Resist Earthquakes," *Proceedings*, World Conference on Earthquake Engineering, University of California, Berkeley, pp. 5-1 to 5-13, 1956.
6. John A. Blume & Associates, *Report of Testing Program on Earthquake Cable Detail for the Preload Company, Inc.*, July 1958. (unpublished)
7. Medearis, K., and Young, D. H., "Energy Absorption of Structures under Cyclic Loading," *ASCE Journal of the Structural Division*, V. 90, ST1, Feb. 1964, pp. 61-89.
8. Uang, C. M., and Bertero, V. V., "Use of Energy as a Design Criterion in Earthquake-Resistant Design," *EERC Report No. UCB/EERC-88*, Nov. 1988.
9. Bertero, V. V., "Energy Based Design Approach", SEAOC, *Performance Based Seismic Engineering of Buildings*, Apr. 1995, pp. D-1 to D-12.
10. Scarlat, A. S., "Design of Soft Stories—A Simplified Energy Approach," *Earthquake Spectra*, V. 13, No. 2, May 1997, pp. 305-315.
11. Newmark, N. M., and Hall, W. J., "Earthquake Spectra and Design," *Earthquake Engineering Research Institute Monograph*, 1982.
12. "Structural Engineering Design Provisions," *Uniform Building Code*, V. 2, International Conference of Building Officials, Whittier, Calif., 1994.
13. New Zealand Standard, "Code of Practice for Concrete Structures for the Storage of Liquids," NZS 3106, 1986.
14. Haroun, M. A., "Stress Analysis of Rectangular Walls Under Seismically Induced Hydrodynamic Loads", *Bulletin of the Seismological Society of America*, V. 74, No. 3, June 1984, pp. 1031-1041.
15. American Society of Civil Engineers, *Guidelines for the Seismic Design of Oil and Gas Pipeline Systems*, prepared by the Committee on Gas and Liquid Fuel Lifelines of the Technical Council on Lifeline Earthquake Engineering, Section 7, 1981.
16. Veletsos, S. A., and Shivakumar, P., "Dynamic Response of Tanks Containing Liquids or Solids," *Computer Analysis and Design of Earthquake Resistant Structures*, Computational Mechanics Publications, Earthquake Engineering Series, V. 3, D. E. Beskos and S. A. Anagnostopoulos, ed. 1997.
17. "AWWA Standard for Wire- and Strand-Wound, Circular, Prestressed Concrete Water Tanks," ANSI/AWWA D110-95, 1995.
18. "AWWA Standard for Circular Prestressed Concrete Water Tanks with Circumferential Tendons," ANSI/AWWA D115-95, 1995.
19. Haroun, M. A., and Ellaithy, H. M., "Seismically Induced Fluid Forces on Elevated Tanks," *Journal of Technical Topics in Civil Engineering*, ASCE, V. III, No. 1, Dec. 1985, pp. 1-15.
20. Applied Technology Council, "Tentative Provisions for the Development of Seismic Regulations for Buildings," *Special Publication No. 510*, U.S National Bureau of Standards, U.S. Government Printing Office, Washington, D.C., 1978.

Notes

APPENDIX A—DESIGN METHOD

RA.1—General outline of design method

In the absence of a more rigorous method of analysis, the general procedures outlined below may be used to apply the provisions of Chapters 1 through 9.

Dynamic lateral forces

1. Calculate the mass of the tank shell (wall) W_w , and roof W_r . Also, compute coefficient ϵ and effective mass, $W_e = \epsilon W_w + W_r$.
2. Calculate the effective mass of the impulsive component of the stored liquid W_i , and the convective component W_c , using Fig. 9.2 for rectangular tanks, or Fig. 9.6 for circular.
3. Calculate the combined natural frequency of vibration, w_i , of the containment structure and the impulsive component of the stored liquid [Eq. (9-9) for rectangular tanks or Eq. (9-23) for circular].
4. Calculate the frequency of the vibration w_c , of the convective component of the stored liquid [Eq. (9-12) for rectangular tanks or Eq. (9-28) for circular].
5. Using the frequency values determined in Steps 3 and 4, calculate the corresponding natural periods of vibration, T_i and T_c [Eq. (9-11) and (9-14) for rectangular tanks; or Eq. (9-25), (9-26), and (9-30) for circular tanks].
6. Select an importance factor I from Table 4(c) and a soil profile coefficient S from Table 4(b).
7. Based on the periods determined in Step 5, calculate the corresponding spectral amplification factors C_i and C_c [Eq. (9-31), (9-32), and (9-33)].
8. Determine the seismic coefficient Z from the seismic zone map, Fig. 4.1, and Table 4(a).

NOTE:

Where a site-specific response spectrum is constructed in accordance with 4.2.1, substitute the site-specific spectral accelerations A_i and A_c for coefficients C_i and C_c (Step 7), S (Step 6) and coefficient Z (Step 8) combined. A_i , representing the effective peak acceleration, is characteristic of short-period structures ($T < 0.31$ s), while A_c , representing the effective peak velocity-related acceleration, is related to long-period structures or structural components (Reference 20).

9. Select the factor R_w specified for the class of structure being investigated (Table 4(d)).
10. Compute the dynamic lateral forces [Eq. (4-1) to (4-4)], and total base shear V [Eq. (4-5)].

Pressure distribution

11. Compute the vertical distribution of the impulsive and convective force components in accordance with Chapter 5.

Overturning moments

12. Calculate the heights h_w , h_r , h_i , and h_c (EBP), and $h_i\zeta$ and $h_c\zeta$ (IBP), to the center of gravity of the tank wall, roof, impulsive component, and convective component respectively (Fig. 9.3, 9.4, 9.7, and 9.8, or Sections 9.2 and 9.3).
13. Calculate the bending and overturning moments [Eq. (4-10) and (4-13)].

COMMENTARY

Vertical acceleration

14. Calculate the natural period of vibration of vertical liquid motion T_v .
15. Calculate the vertical amplification factor C_v as a function of T_v .
16. Calculate the hydrodynamic pressure p_{hy} using Eq. (4-14)

Stresses

17. In rectangular tanks, calculate the stresses in the wall due to the impulsive and convective pressures, depending on the structural system considered (6.1), and the stresses associated with the increase in effective fluid density due to the vertical acceleration.
18. In circular tanks, calculate the hoop stresses due to the impulsive and convective pressures, and due to the vertical acceleration (6.2).
19. Calculate the overall bending stresses due to the overturning moments (from Step 13). Downward pressures on the neoprene bearing pads of free base circular tanks caused by overturning moments should be considered. If uplift develops on the heel side, then anchor cables must be provided.